

Pg. 58

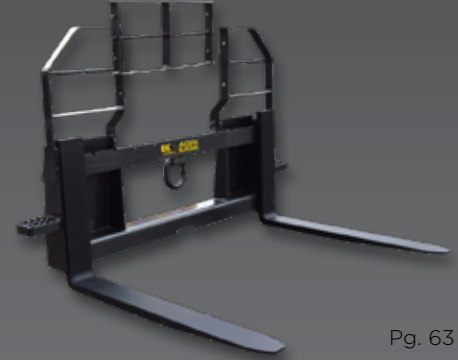

Pg. 17



Pg. 63



Pg. 39



Pg. 76



Pg. 79



Pg. 95



Pg. 83



## BRABER EQUIPMENT

### 50th Anniversary

*Quality, Service, Support & Innovation*

PH 604.850.770 FAX 604.850.774

TOLL FREE 1.877.588.3311 TOLL FREE FAX 1.800.665.7334

WGSALES@BRABEREQ.COM



**BRABER EQUIPMENT**

**50th Anniversary**

*Quality, Service, Support & Innovation*



4	PLOWS AND POTATO LIFTERS
5-6	CULTIVATORS
7	AERATORS & FLAT BALLAST ROLLERS
8	DISC HARROWS
9-10	REAR BOX BLADES
11	FRONT BLADES & SNOW PUSHER BLADES
12	BOX BLADES
13	BOX GRADER SCRAPERS & LANDSCAPE RAKES
14	3PT HITCH BACKHOES
15-16	FINISH MOWERS
17-18	ROTARY CUTTERS
19-21	FLAIL & BOOM MOWERS
22	BRUSH RAKES
23	SHREDDERS
24-27	TEDDER RAKES
28-34	BRUSH RAKES
35	SICKLE MOWERS
36	DISC MOWERS
37-46	ROTARY TILLERS
47-54	HARROWS
55-57	FERTILIZER SPREADERS
58-62	SKID STEER ATTACHMENTS
63-67	PALLET FORKS
68	TOW HOOKS
69-70	BALE SPEARS
71	SUBSOILERS & MIDDLEBUSTERS
72-77	LOGSPLITTERS
78-80	SNOWBLOWERS
81	WOOD CHIPPER
82-83	POST HOLE DIGGERS
84-95	SPRAYERS
96-98	LAWN & GARDEN

### Plow

BE-P2BFK

#### Standard Plows

PART #	BE-P1BFK	BE-P2BFK
WEIGHT	253 LBS	462 LBS
HP RATING	15-30	30-40
COULTERS	1	2

#### Heavy-Duty Plow

PART #	BE-P3BFK
WEIGHT	775 LBS
HP RATING	40-60
COULTERS	3

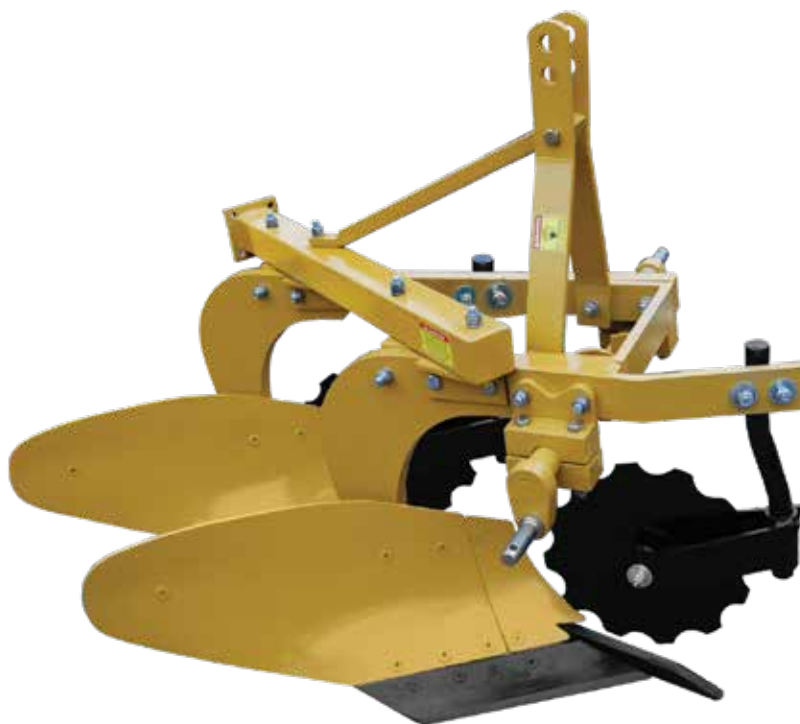

### 3pt Hitch Potato Lifter

CHM-SP50

#### Features

- Category 1, 3PT hitch
- 540 RPM PTO
- Front coulters
- Depth wheels

#### 3PT Hitch Potato Lifter

PART #	CHM-SP50
WEIGHT	353 LBS
DISCHARGE	REAR
HP REQUIRED	18
HITCH	CENTER



### S-Tine Cultivator

BE-FC06ST



#### Features

- Category 1, 3 PT hitch
- Reversible points
- Adjustable spacing
- 1 bolt shank adjustment
- Forged steel S-tines
- Solid welded frame

S-Tine Cultivator			
PART #	BE-FC05ST	BE-FC06ST	BE-FC07ST
WEIGHT	185 LBS	210 LBS	240 LBS
CUTTING WIDTH	60"	72"	84"
S-TINES	9	11	13

### 1 Row Cultivator

With Spring Shanks  
BE-FC1RG



#### Features

- Category 1, 3 PT hitch
- 6 spring shanks tines
- Reversible points

1 Row Cultivator	
PART #	BE-FC1RG
WEIGHT	118 LBS
CUTTING WIDTH	48"
TINES	6

### Cultivator Heavy-Duty

Spring Tine Loaded

BE-FC9S



#### Features

- Category 1, 3 PT hitch
- Double coil spring tines
- 2 1/4" X 12" reversible shovels
- Solid welded frame
- New heavy duty shanks

#### Heavy-Duty Spring Tine Loaded Cultivators

PART #	BE-FC5S	BE-FC7S	BE-FC9S	BE-FC11S
WEIGHT	350 LBS	450 LBS	575 LBS	700 LBS
WIDTH	3'6"	5'6"	7'	8'
HP RATING	20-40 HP	20-40 HP	30-50 HP	30-50 HP
TINES	5	7	9	11

### Cultivator Soil Conditioner

BE-FCH05R



#### Features

- Category 1, 3 PT hitch
- Wide sweeps
- Adjustable spacing
- Leveling bar with spiked teeth
- Spring loaded cage roller

#### Cultivator Soil Conditioner

PART #	BE-FCH04R	BE-FCH05R	BE-FCH06R
WEIGHT	451 LBS	564 LBS	677 LBS
WORKING WIDTH	48"	60"	72"
S-TINE	7	9	11

ALSO AVAILABLE WITHOUT ROLLER AND SPIKES (BE-FC05)

## 48" Aerator

BE-AER4G



### Features

- Category 1, 3PT hitch
- 1' diameter main shaft
- Oil impregnated spool wheel bearings for longer life
- 3/4" closed spoons, 6 spoons per wheel
- Heavy steel mesh protector shield
- Coring pattern 5" x 9.5"

Aerators			
PART #	BE-AER4G	BE-AER5G	BE-AER6G
WEIGHT	370 LBS	410 LBS	450 LBS
CORNING WIDTH	48"	60"	72"
HP RATING	440 LBS	660 LBS	800 LBS
# OF SPOONS	60	72	84
# OF SPOON WHEELS	10	12	14

## 59" Flat Ballast Roller

BE-FBR150

### Features

- 3PT hitch
- Used for soil compaction
- Includes 3 removable and adjustable aerator spikes
- Water fill to increase ballast weight
- Parking stand



BE-FBR150	
HP RATING	20 - 50 HP
WEIGHT	375 LBS
WORKING WIDTH	59"

### Disc Harrow

BE-DH1216N

#### Features

- Category 1, 3PT hitch
- Notched front discs
- Plain rear discs
- Regreaseable cast iron bearings
- Tubular iron frame



DISC HARROWS		
PART #	BE-DH1216N	BE-DH1618N
WEIGHT	410 LBS	475 LBS
CUTTING WIDTH	4' 2"	4' 11"
HP RATING	UP TO 40 HP	UP TO 40 HP
BLADE SIZE	16" DIA	18" DIA

### Disc Harrow

BE-DH210FK

#### Features

- Cat 1, 3PT hitch
- 40-70 HP
- Notched front and rear discs with scrapers
- Heavy duty tubular frame
- Adjustable cut



Standard Disc Harrows			
PART #	BE-DH185FK	BE-DH210FK	BE-DH230FK
WEIGHT	590 LBS	862 LBS	1034 LBS
CUTTING WIDTH	4' 6"	6'	7' 2"
BLADE SIZE	18" DIA	18" DIA	18" DIA



## 5ft Rear Blade

BE-RBR5G

### Features

- Category 1, 3PT hitch
- Up to 50 HP rating
- 6" reversible cutting edges
- 14-1/2" moldboard height
- Parking stand
- 5 adjustable positions
- 3/16" thick reinforced moldboards
- 3 position tilt
- Angle & reverse adjustment



Rear Blades					
PART #	BE-RBR4G	BE-RBR45G	BE-RBR5G	BE-RBR6G	BE-RBR7G
WEIGHT	170 LBS	205 LBS	205 LBS	230 LBS	255 LBS
WIDTH	4 FT	5 FT 6"	5 FT	6 FT	7 FT
HP RATING	UP TO 50 HP	UP TO 50 HP	UP TO 50 HP	UP TO 50 HP	UP TO 50 HP
MOLDBOARD CUTTING EDGE	6"	6"	6"	6"	6"
MOLDBOARD HEIGHT	14 FT 6"	14 FT 6"	14 FT 6"	14 FT 6"	14 FT 6"
MOLDBOARD THICKNESS	3/16"	3/16"	3/16"	3/16"	3/16"

## 7ft Rear Blade

Heavy-Duty

BE-RB207HD

### Features

- 90° bend at top of blade
- Double gusseting for ultra strength
- 1/4" thick reinforced moldboards
- 1/2" x 6" reversible cutting edge
- Quick hitch compatible
- Up to 60 HP rating
- Angle and reverse adjustment
- Category 2, 3PT hitch



Rear Blades			
PART #	BE-RB206HD	BE-RB207HD	BE-RB208HD
WEIGHT	330 LBS	350 LBS	370 LBS
WIDTH	6 FT	7 FT	8 FT
HP RATING	UP TO 60 HP	UP TO 60 HP	UP TO 60 HP
MOLDBOARD CUTTING EDGE	6"	6"	6"
MOLDBOARD HEIGHT	14 FT 6"	14 FT 6"	14 FT 6"
MOLDBOARD THICKNESS	1/4"	1/4"	1/4"



**NEW AND IMPROVED REAR GUSSETS FOR ADDED REINFORCEMENT**

### 8' Heavy Duty Rear Blade

With Hydraulic Angle  
BE-RB408HDG

#### Features

- Category 2, 3PT hitch
- Reversible cutting edge
- Angle hydraulic cylinder with hoses
- For tractors up to 80 hp
- Reversible blade, Adjustable positions
- Reinforced moldboard
- Mechanical link for tilt and offset



Heavy Duty Rear Blade	
PART #	BE-RB408HDG
WEIGHT	970 LBS
WIDTH	8 FT
HP RATING	UP TO 80 HP
MLDB. HEIGHT	18"
MLDB. THICK.	5/16"
CUTTING EDGE	6"

### 9' Heavy Duty Rear Blade

with Hydraulic Angle  
BE-RB409HDG

#### Features

- Category 2, 3PT hitch
- Reversible cutting edge
- Angle hydraulic cylinder with hoses
- For tractors up to 80 hp
- Reversible blade, Adjustable positions
- Reinforced moldboard
- Mechanical link for tilt and offset



Heavy Duty Rear Blade	
PART #	BE-RB409HDG
WEIGHT	1060 LBS
WIDTH	9 FT
HP RATING	UP TO 80 HP
MLDB. HEIGHT	18"
MLDB. THICK.	5/16"
CUTTING EDGE	6"

Options			
PART #	RBHYDSHOE-SET	BE-RB408TILCYL	BE-RB400FFSETKIT
DESCRIPTION	SKID SHOES	TILT CYLINDER	OFFSET CYLINDER

## 6' Front Blade

Heavy Duty Skid Steer  
BE-FBS6B0500

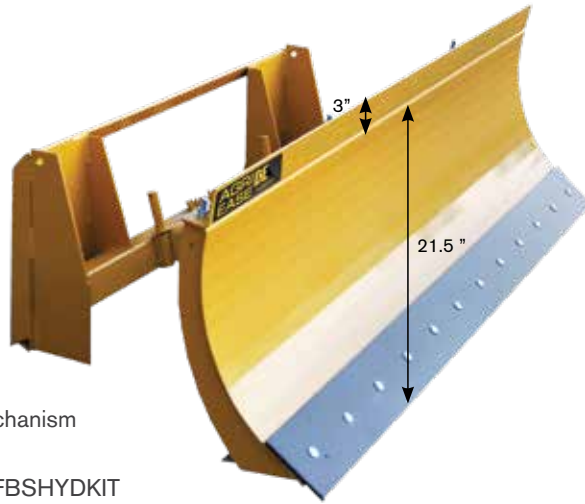

### Features

- Adjustable skid shoes
- Reversible cutting edge
- Manual angle adjustment
- Includes spring trip safety mechanism
- Skid steer mount
- Optional hydraulic angle kit - FBSHYDKIT
- Yellow or black (part# BK) finish

## Hydraulic Angle Kit

FBSHYDKIT

### SKID STEER MOUNT



Heavy Duty Front Blade						
PART #	BE-FBS5B0500	BE-FBS5B0500BK	BE-FBS6B0500	BE-FBS6B0500BK	BE-FBS7B0500	BE-FBS7B0500BK
WEIGHT	385 LBS	385 LBS	420 LBS	420 LBS	470 LBS	470 LBS
WIDTH	5 FT	5 FT	6 FT	6 FT	7 FT	7 FT
HP RATING	UP TO 60 HP	UP TO 60 HP	UP TO 60 HP	UP TO 60 HP	UP TO 60 HP	UP TO 60 HP

## 84" Snow Pusher

Front Mount, 7'  
BE-SPBB07

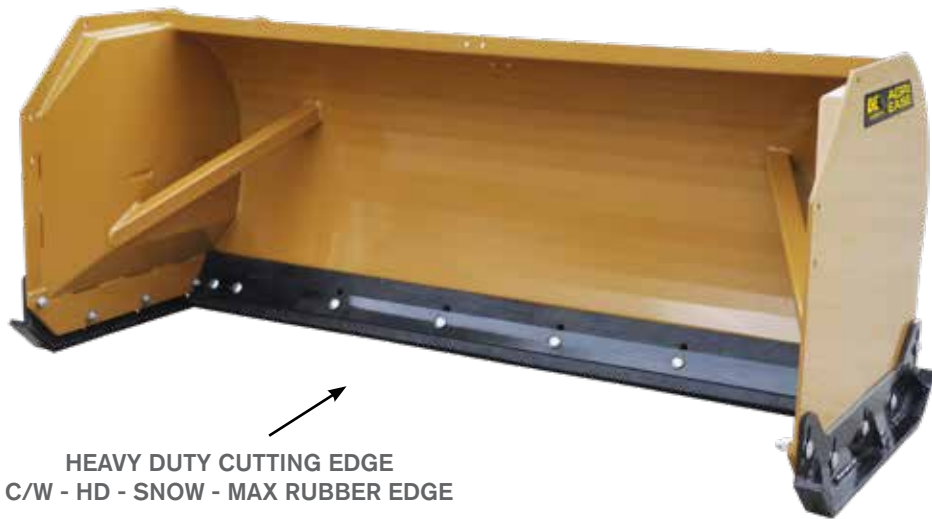

Snow Pusher Blade			
PART #	BE-SPBB06 72"	BE-SPBB07 84"	BE-SPBB08 96"
DESCRIPTION	SNOW PUSHER 6' S/S	SNOW PUSHER 7' S/S	SNOW PUSHER 8' S/S
WEIGHT	625 LBS	675 LBS	725 LBS

### 7ft Box Blade

BE-BBR7G

#### Features

- Category 1, 3PT hitch
- Replaceable cutting edge
- Adjustable spring steel shanks
- 17" moldboard height
- Reversible 1/2" x 6" cutting edges



Box Blades							
PART #	BE-BBR4G	BE-BBR45G	BE-BBR5G	BE-BBR55G	BE-BBR6G	BE-BBR7G	BE-BBH8G
WEIGHT	368 LBS	398 LBS	446 LBS	475 LBS	496 LBS	584 LBS	740 LBS
WIDTH	4 FT	54"	5 FT	5 FT 6"	6 FT	7 FT	8 FT
HP RATING	UP TO 50 HP	UP TO 50 HP	UP TO 50 HP	UP TO 50 HP	UP TO 50 HP	UP TO 50 HP	UP TO 70 HP
NO OF SHANKS	4	4	5	5	6	7	8
MOLDBOARD HEIGHT	17"	17"	17"	17"	17"	17"	17"
SIDE PANEL THICKNESS	3/8"	3/8"	3/8"	3/8"	3/8"	3/8"	1/2"

### 3PT Hydraulic Box Blade

BE-BBHH6

#### Features

- Category 1, 3PT hitch
- Hydraulic retractable steel shanks
- Floating tailgate on F model only
- Reversible cutting edge
- For tractors up to 70HP
- Extra heavy duty shanks & tips



3PT Hydraulic Box Blades	
PART #	BE-BBHH6
WEIGHT	575 LBS
WORKING WIDTH CM/IN	183/72
HP RATING	40-50
SIDE PANEL THICKNESS	1/4"
NO. OF SHANKS	6
MOLD BOARD HEIGHT	19"
HITCH	CAT 1

## 60" Box Grader Scraper

BE-GS05G

### Features

- 5 reversible positions
- Category 1, 3PT hitch
- Adjustable, 3 position shanks
- Reinforced side panels
- 6 1/2" x 6" heat treated reversible beveled cutting edges
- 3 position grading angle to work on any surface
- For tractors up to 60 HP



**NEW DOUBLE CUTTING EDGE!**

Box Scraper					
PART #	BE-GS045G	BE-GS05G	BE-GS06G	BE-GS07G	BE-GS08G
WEIGHT	465 LBS	515 LBS	605 LBS	690 LBS	780 LBS
WIDTH	54"	60"	72"	84"	96"
HP RATING	15-45	20-45	25-50	25-60	35-60
MOUNT	3 PT	3 PT	3 PT	3 PT	3 PT
# SHANKS	4	4	5	6	7

## 3 Point Landscape Rake

BE-LRM5G

### Features

- Category 1, 3PT hitch
- 5 forward & 5 reverse settings
- 5/16" x 1" x 17" spring tines



Landscape Rakes			
PART #	BE-LRM5G	BE-LRM6G	BE-LRM7G
WEIGHT	255 LBS	280 LBS	310 LBS
WORKING WIDTH	5 FT	6 FT	7 FT
HP RATING	50 HP	50 HP	50 HP

### Optional

WHEEL KIT PART# BE-LRMWKIT



Backhoes			
MODEL		BK61	BK76
DIGGING DEPTH (TWO FOOT FLAT BOTTOM)	A	6'1"	7'6"
REACH FROM CENTER LINE OF SWING PIVOT	B	19'3"	10'9"
LOADING HEIGHT (BUCKET AT 60°)	C	5'3"	6'8"
MAXIMUM LEVELING ANGLE	D	10°	10°
SWING ARC	E	180°	180°
TRANSPORT HEIGHT (MAXIMUM)	F	6'2"	6'4"
TRANSPORT OVERHANG	G	3'8"	4'4"
BUCKET ROTATION	H	180°	180°
STABILIZER SPREAD (DOWN POSITION)	I	5'8"	5'8"
STABILIZER SPREAD (UP POSITION)	J	4'4"	4'4"
ANGLE OF DEPARTURE	K	21°	21°
SHIPPING WEIGHT		948 LBS	1020 LBS
BUCKET DIGGING FORCE		2315 LBS	2600 LBS
DIPPERSTICK DIGGING FORCE		1543 LBS	1900 LBS
OPERATING PRESSURE		2300 PSI	2300 PSI
MIN HP		20-50HP	40-100HP



- 12" BUCKET INCLUDED
- WITH ITALIAN CONTROL VALVE, VERY COMFORTABLE OPERATING
- BKHYDKIT (DEALER INSTALLED OPTION ONLY) .....
- BKPAD .....
- BK8 - 8" BUCKET .....
- BK16 - 16" BUCKET.....
- BKSTB .....
- BKTHUMB - MECHANICAL THUMB .....

**\*BK215 – Remote Hydraulics**

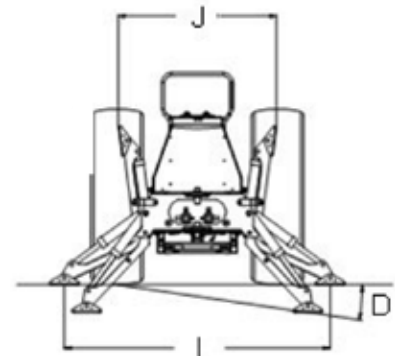
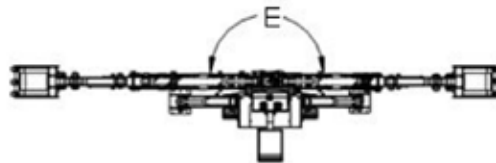
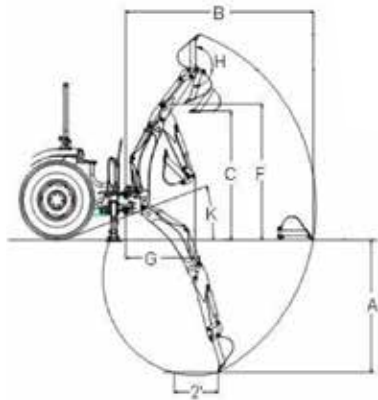

OPTIONAL  
BKSTB STABILIZER KIT

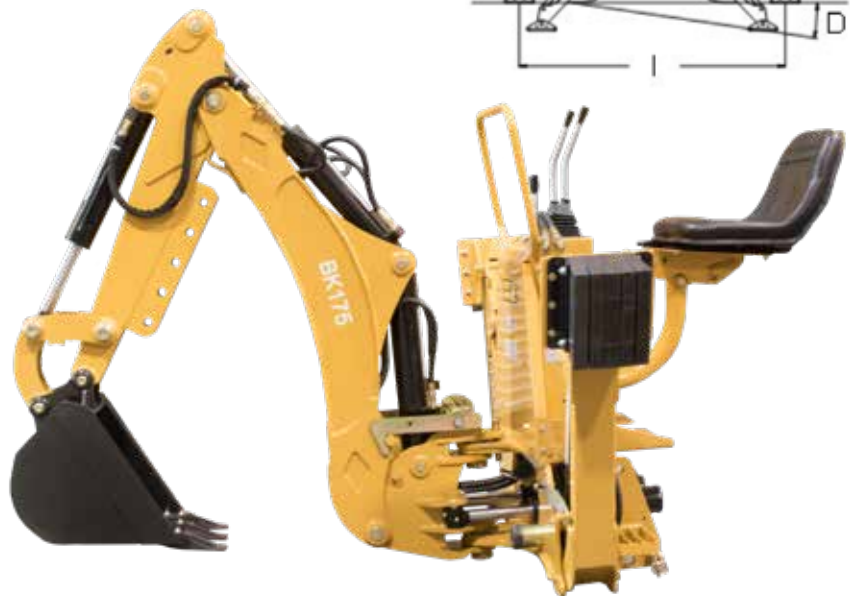

### 60" Rear Finish Mower

BE-FM60RDG



#### Features

- 540 RPM PTO
- Floating hitch
- Cutting height 1"- 4"
- Category 1, 3PT hitch
- 4 height adjustable wheels
- Single piece formed deck
- Easy access to grease points
- Easy service ability

Finish Mowers / Standard			
PART #	BE-FM48RDG	BE-FM60RDG	BE-FM72RDG
WEIGHT	310 LBS	360 LBS	460 LBS
WIDTH	48"	60"	72"
HP RATING	15 HP	20 HP	30 HP
PTO	540	540	540
BLADES	3	3	3

### 72" Finish Mower

MAS-FM180RD



#### Features

- Category 1, 3PT hitch
- 4 Height adjustable wheels
- PTO speed 540 RPM
- Cutting height 1"- 4"
- Floating hitch
- Single piece formed deck
- Easy access grease points
- Easy service ability

Finish Mowers				
PART #	MAS-FM120RD	MAS-FM150RD	MAS-FM180RD	MAS-FM210RD
WEIGHT	370 LBS	418 LBS	506 LBS	803 LBS
WORKING WIDTH	48"	60"	72"	83"
HP RATING	14	20	30	35
BLADES	3	3	3	SWING BLADES, 6/3 SPINDLES

### 60" Rear Finish Mower

Heavy Duty Deluxe  
BE-FM60RDGS

#### Features

- Foam filled wheels
- HD blade spindlers
- HD blades
- 4 mm deck thickness
- HD wheel bearing
- Belt driven spindles



Finish Mowers / Heavy-Duty			
PART #	BE-FM48RDGS	BE-FM60RDGS	BE-FM72RDGS
WEIGHT	355 LBS	410 LBS	520 LBS
WIDTH	48"	60"	72"
HP RATING	15 HP	20 HP	30 HP
PTO	540	540	540
BLADES	3	3	3



### 84" Heavy-Duty Finish Mower

BE-FM84RDHDG

#### Features

- Heavy duty gearbox
- 3" wide x 10" DIA solid rubber tires
- Belt drive
- Safety guards
- 4 height adjustable wheels
- Category 1,2; 3PT hitch
- Cutting height: 1 $\frac{3}{4}$ " - 4  $\frac{3}{4}$ "
- Easy access grease points
- Floating hitch
- Single piece formed deck
- HD cast iron housing with permanent greased ball bearing



HD Finish Mowers	
PART #	BE-FM84RDHDG
WEIGHT	728 LBS
WIDTH	84"
HP RATING	45 HP
BLADES	3





## 60" Rotary Cutter

BE-RC500G

### Features

- Adjustable cutting height with a flexible floating hitch for even adjustable cut
- Category 1, 3PT hitch
- 540 RPM 50HP shearbolt PTO included
- HD laminated tail wheel to help eliminate scalping
- Heavy duty deck and side beams
- Rear safety chain
- Underside has 2 blades with stump protection
- 50 HP gearbox with 6 year warranty



Rotary Cutters						
<b>PART #</b>	BE-RC40-2G	BE-RC400G	BE-RC450G	BE-RC500G	BE-RC550G	BE-RC600G
<b>WEIGHT</b>	400 LBS	482 LBS	545 LBS	605 LBS	665 LBS	725 LBS
<b>CUTTING WIDTH</b>	40"	48"	54"	60"	66"	72"
<b>CUTTING HEIGHT</b>	1 TO 8"	1 TO 8"	1 TO 8"	1 TO 8"	1 TO 8"	1 TO 8"
<b>PTO</b>	SHEARBOLT	SHEARBOLT	SHEARBOLT	SHEARBOLT	SHEARBOLT	SHEARBOLT
<b>BLADES</b>	2	2	2	2	2	2
<b>HP RATING</b>	• FOR TRACTORS UP TO 50 HP					

## Round Back Rotary Cutter

72" Rough Cut

BE-RCR600G

### Features

- Adjustable cutting height
- Category 1, 3pt hitch
- Quick hitch compatible
- HD laminated tail wheel to help eliminate scalping
- HD 3.5mm round back deck and side panels
- Rubber front and rear guards
- Underside has 2 blades with stump protection
- Angled front corners
- 6 Year gearbox warranty



Round Back Rotary Cutters				
<b>PART #</b>	BE-RCR350G	BE-RCR400G	BE-RCR500G	BE-RCR600G
<b>WEIGHT</b>	450 LBS	490 LBS	540 LBS	640 LBS
<b>WIDTH</b>	42"	48"	60"	72"
<b>HP RATING</b>	20-50 HP	20-50 HP	20-50 HP	20-50 HP
<b>PTO</b>	SHEARBOLT	SHEARBOLT	SHEARBOLT	SHEARBOLT
<b>BLADES</b>	2	2	2	2

### Round Back Heavy Duty Rotary Cutter

70 HP Gearbox with Slip Clutch PTO, 6' Heavy Duty BE-RC6HDG



#### Features

- Category 1, 3PT hitch
- Free swinging blades
- Rear safety chains
- Floating hitch
- 70 HP gearbox with 6 year warranty
- Heavy duty laminated tail wheel to help eliminate scalping
- Adjustable cutting height 1" to 8"
- Heavy duty deck & side beams
- 540 RPM slip clutch PTO included
- Underside has 2 blades with stump protection

#### \* HDG Heavy Duty Models

HD round deck, HD A-frame, HD gearbox

HD Rotary Cutters			
PART #	BE-RC5HDG	BE-RC6HDG	BE-RC7HDG
WEIGHT	700 LBS	840 LBS	1365 LBS
CUTTING WIDTH	5'	6'	7'
PTO	SLIP CLUTCH	SLIP CLUTCH	SLIP CLUTCH
BLADES	2	2	2
HP RATING	FOR TRACTORS UP TO 70 HP		

### Flail Mower

BE-EFGC155F



#### Features

- Category 1 & 2; 3PT hitch
- 540 RPM PTO
- Side belt drive
- Adjustable skid shoes
- Fixed centre hitch



GRASS BLADES

Flail Mowers								
PART #	BE-EFG95F	BE-EFGC105F	BE-EFGC125F	BE-EFGC145F	BE-EFGC155F	BE-EFGC165F	BE-EFGC175F	BE-EFGC200F
WEIGHT	407 LBS	462 LBS	485 LBS	699 LBS	732 LBS	765 LBS	791 LBS	826 LBS
WORKING WIDTH	38"	42"	48"	56"	60"	64"	68"	78"
OFFSET	0"	0"	0"	0"	4"	8"	12"	22"
HP RATING	18 HP	18 HP	18 HP	18-35 HP	20-35 HP	25-40 HP	25-40 HP	30-45 HP
GRASS BLADES	34	36	40	44	48	52	56	60

### 39" Agriease Flail Mower

With Fixed Hitch  
CAR-TL900



TL BLADE



TM BLADE

#### Features

- Adjustable skids
- Skid shoes
- Category 1, 3PT hitch
- Full width rear rollers
- Side belt drive with spring tightener
- Steel front guards
- Double flail blades
- Optional hydraulic shift kit for CAR-TL1500 and CAR-TM1900

TL Series Flail Mower			
PART #	CAR-TL900	CAR-TL1200	CAR-TL1500
WEIGHT	400 LBS	412 LBS	472 LBS
WIDTH	39"	49"	59"
HP RATING	20-40 HP	20-40 HP	20-40 HP
BLADES	28	36	44
HITCH	FIXED	FIXED	FIXED



### 53" Agriease Flail Mower

With Adjustable Hitch  
CAR-TM1300

#### Features

- Category 1, 3PT hitch
- Full width rear rollers
- Double flail blades
- Adjustable hitch
- Side belt drive with spring tightener
- Steel front guards
- Adjustable skids

TM Series Flail Mower			
PART #	CAR-TM1300	CAR-TM1600	CAR-TM1900
WEIGHT	507 LBS	562 LBS	644 LBS
WIDTH	53"	63"	73"
HP RATING	20-60 HP	20-60 HP	30-60 HP
BLADES	40	48	56
HITCH	ADJUSTABLE	ADJUSTABLE	ADJUSTABLE



**Optional Hydraulic ADJ Hitch Kit (CAR-TML01HYD)**

## MASCHIO

### 3PT Hitch Boom Flail

With Fixed Hitch  
MAS-GIRAFFA185



#### Features

- Category 2,3; 3PT hitch
- 540 RPM PTO
- Full width roller
- Skids
- Side belt drive
- Upper toothed counter-blades
- Hydraulic for side or incline offset
- Front safety shields
- Lower counter blades
- Will cut up to 65° ditch bank
- Cuts up to 1-1/2" thick material
- Constant velocity PTO shaft

### 3PT Hitch Boom Mower

BE-AGF140



#### Features

- Sidebelt drive shield
- Hydraulic offset hitch
- Will cut up to 45° ditch bank
- Category 2, 3PT hitch
- 540 RPM PTO
- Full width roller
- Adjustable skid shoes



BLADE



HAMMER BLADE

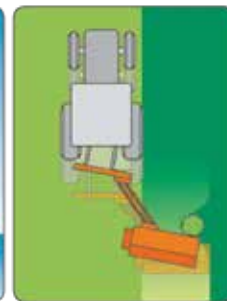
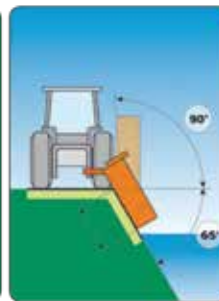
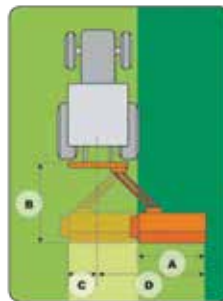

	Giraffa 3pt Boom Flails			3PT Hitch Boom Mower
PART #	MAS-GIRAFFA160	MAS-GIRAFFA185	MAS-GIRAFFA210*	BE-AGF140
WEIGHT	1,210 LBS	1,276 LBS	1,364 LBS	1,080 LBS
WIDTH	62"	75"	84"	54"
TOTAL WIDTH	70"	91"	100"	
HP RATING	40-80 HP	60-80 HP	70-80 HP	40-85 HP
OPTIONAL BLADE	36	48	60	48
STANDARD HAMMER	18	24	30	24
HITCH	ADJUSTABLE	ADJUSTABLE	ADJUSTABLE	

▪ \*Available with inside or outside gearbox  
▪ (AS-GIRAFFA210 only)

## CESARI

### Orchard Brush Rake

CES-RC170SP



#### Features

- Mechanical buffer with rubber bumper
- 540 RPM PTO
- For windrow pruning
- Side delivery
- Shear bolt protection
- 3PT Hitch

Orchard Brush Rakes			
PART #	CES-RC140SP	CES-RC170SP	CES-RC200SP
WEIGHT	608 LBS	642 LBS	664 LBS
KW	21	21	21
HP RATING	28 HP	28 HP	28 HP
RAKE SWATH	55"	67"	79"

HYDRAULIC DRIVEN FRONT MOUNT MODEL AVAILABLE!

STARTING AT

The TFB forage model has a reduced body height of 50 cm. This lends well to the pruning of shrubs as well as to the cleaning of orchards, olive groves, and vineyards. The robust steel rotor is helical in configuration, electronic, mounted on bearing chucks, and perfectly protected.

## TFBHVDSET HYD Offet Kit TFB1600 + LARGER

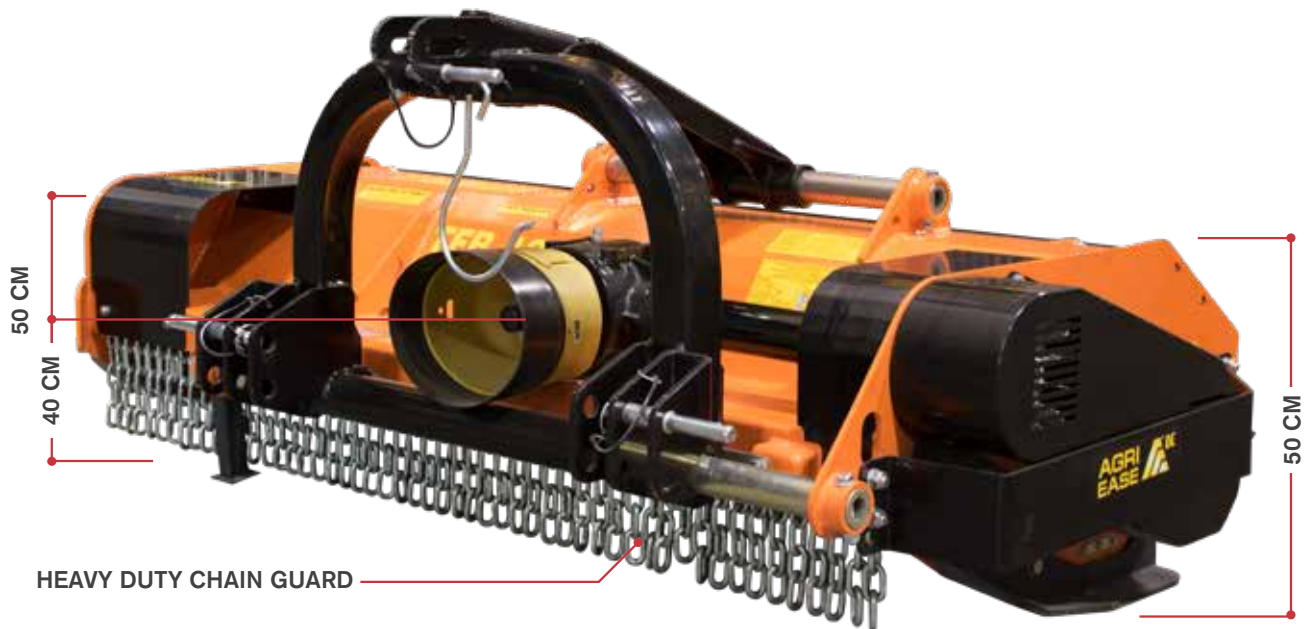

STANDARD SUPPLY: ADJUSTABLE HAMMERS, ADJUSTABLE LEVELING ROLLER, COUNTER BLADES, CE SAFETY PROTECTIONS, ADJUSTABLE BELT-TENDER, MECHANICAL SIDE-SHIFT, OPENABLE REAR HOOD, GEARBOX WITH FREE-WHEEL CLUTCH, SUPPORT SIDES, AND DOUBLE HOUSING.

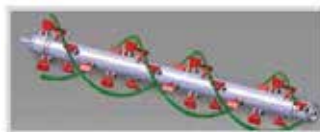

STANDARD: NEW CUTTING SYSTEM WEAR PLATE ALREADY WELDED TO THE FRAME

TFB Shredders			
PART #	WORKING WIDTH (CM)	HP	LBS
BE-TFB1200	120	30-40	1080
BE-TFB1400	140	35-60	1124
BE-TFB1500	150	40-70	1190
BE-TFB1600	160	40-70	1256
BE-TFB1800	180	50-70	1300
BE-TFB2000	200	60-80	1433
BE-TFB2200	220	70-90	1521
BE-TFB2400	240	80-100	1631
BE-TFB2600	260	90-100	1741
BE-TFB3000	300	110-150	1984
BE-TFBHYDSFT			

### FELLA

#### Pull Type Rotary Tedder

FEL-TH540T



#### Features

- Pull type
- 540 RPM PTO
- Floating hex main shaft
- Quiet and smooth running
- Heavy duty gearbox, hitch and draw bar
- Jack stand
- Simple transport and working adjustments
- Large, rigid rotor discs
- Anti-wrap covers on inner wheels
- Simple spread angle adjustments
- 6 tine arms per rotor
- Anti-tine loss protection
- Overload safety clutch (radial pin clutch)
- Warning panels
- Hydraulic fold (up)

Pull Type Rotary Tedders	
PART #	FEL-TH540T
WEIGHT	1,221 LBS
HP RATING	30 HP
CUTTING WIDTH	17'
TRANSPORT WIDTH	9' 9"
PARKING HEIGHT	8' 9"
ROTORS	4
TIRE SIZE	2 X 16/6.50-8" 2 X 16/8.50-8"

Optional
ELECTRICAL LIGHTING



## FELLA

### Pull Type Rotary Tedder

FELTH790HYD



#### Features

- 540 RPM PTO
- Floating hex main shaft
- Quiet smooth running
- Heavy duty gearbox
- Jack stand
- Simple transport and working adjustments
- Heavy duty hitch and draw bar
- Large rigid rotor discs
- Anti-wrap covers on inner wheels
- Simple spread angle adjustments
- 6 tine arms per rotor
- Anti-tine loss protection
- Overload safety radial pin clutch (friction clutch on FEL-TH1300HYD)

#### Pull Type Rotary Tedders

PART #	FEL-TH790HYD
WEIGHT	1,958 LBS
HP RATING	41 HP
CUTTING WIDTH	25'3"
TRANSPORT WIDTH	9'1"
TRANSPORT LENGHT	18'4"
ROTORS	6
TIRE SIZE	16/6.50-8"
HYDRAULIC FOLD	YES

#### Optional

ELECTRICAL LIGHTING

WARNING PANELS



## FELLA

### Semi Mount Rotary Tedders

FEL-TH11008TRANS



#### Features

- Semi mount
- 540 RPM PTO
- Floating hex main shaft
- Quiet, smooth running
- Heavy duty gearbox, hitch and draw bar
- Jack stand
- Simple transport and working adjustments
- Large rigid rotor discs
- Anti-wrap covers on inner wheels
- Simple spread angle adjustments
- Automatic shut-off on hydraulic fold units
- Warning panels
- Electrical lighting
- Overload safety clutch in the auxiliary drive (radial pin clutch)
- Anti-tine loss protection
- 6 tine arms per rotor
- Draw bar (FEL-TH800TRANS), Category 2 (FEL-TH11008TRANS)

Semi Mount Rotary Tedders	
PART #	FEL-TH11008TRANS
WEIGHT	3,687 LBS
HP RATING	54 HP
CUTTING WIDTH	33'6"
TRANSPORT WIDTH	9'10"
TRANSPORT LENGHT	15'8"
ROTORS	8
TIRE SIZE	6 X 16/6.50-8" 2 X 18.5/8.50-8"
CHASSIS TIRES	10.0/80-12

### FELLA

#### Trailed Tedder With Transport Chassis

FEL-TH13010TRANS



#### Features

- 6 tine arms per rotor
- Anti-tine loss protection
- Rotor tires: 8 x 16/6.50-8, 2 x 18.5/8.50-8
- Chassis tires: 10.0/75-15.3
- 540RPM PTO
- Warning panels
- Electrical lighting
- Hydraulic fold-up

#### Trailed Tedder With Transport Chassis

Trailed Tedder With Transport Chassis	
PART #	FEL-TH13010TRANS
WEIGHT	4,410 LBS
HP RATING	90 HP
CUTTING WIDTH	41'8"
TRANSPORT WIDTH	9'10"
TRANSPORT LENGTH	18'4"
ROTORS	10

## FELLA

### Single Rotary Rake

FEL-TS456T



#### Features

- 540 RPM PTO
- 16/6.50-8 tires
- Rotor height adjustment remote control
- RH swath delivery
- Heavy duty greaseable gearbox
- Optimum swath formation
- Closed camtrack with ball bearing steel rollers
- Detachable tine arm for horizontal storage
- Enclosed full tangential guidance
- Swivelling headstock
- Category 1, 2  
(except FEL-TS425T - draw bar)
- Overload safety clutch
- Standard tandem axle

## FELLA

### Single Rotary Rake

FEL-TS351DN

Single Rotary Rakes		
PART #	FEL-TS351DN	FEL-TS456T
WEIGHT	924 LBS	1,309 LBS
HP RATING	27 HP	41 HP
CUTTING WIDTH	11'10"	14'9"
TRANSPORT WIDTH	5'1"	6'6"
TRANSPORT LENGTH	7'3"	11'9"
SWATH WIDTH	2'-12'6"	6'3"-13'4"
TINE ARMS PER ROTOR	10	12
DOUBLE TINES PER ARM	3	4
HITCH	3 PT	PULL TYPE

Optional	
ELECTRICAL LIGHTING, WARNING PANELS, TANDEM AXLE	



## FELLA

### Dual Rotary Rakes

FEL-TS8055PRO



#### Features

- Category 2,3
- Fixed twin jockey wheels on the rotor chassis
- Standard tandem axle
- Tires of rotor chassis: 6 x 18/8.50-8
- Tires of transport chassis: 300/80-15.3, 11.5/80-15.3 AW
- 4 double tines per arm
- 540RPM PTO
- Standard type PTO shaft
- Overrunning clutch in the auxiliary drive
- Warning panels
- Electrical lighting

Dual Rotary Rake	
PART #	FEL-TS8055PRO
WEIGHT	4400 LBS
HP RATING	48 HP
CUTTING WIDTH	23'7"
TRANSPORT LENGTH	17'7"
TRANSPORT WIDTH	9'9"
TRANSPORT HEIGHT DTA*	11'10"
PARKING HEIGHT	3'11"-6'11"
TINE ARMS PER ROTOR	12

\*dta- dismantled tine arms



the FEL-TS8055PRO pro has been developed for applications with extreme loads and for optimum adjustment to the ground contours

## FELLA

### Dual Rotary Rake Side Delivery and Center Swathing

FEL-TS1402



#### Features

- 540 RPM PTO
- Tandem axles
- Jack stand
- HD removable arms
- Simple swath/height adjustment
- Wide angle, one-sided PTO shaft
- Overrunning clutch in the auxiliary drive
- Warning panels
- Electrical lighting
- Semi-mount hitch
- Single or double swath

#### Dual Rotary Rake

PART #	FEL-TS1402
WEIGHT	3,410 LBS
HP RATING	40 HP
WORKING WIDTH	18'10" - 25'3"
ROTOR DIAMETER	9' & 9'1"
TRANSPORT LENGTH	21'9"
TRANSPORT WIDTH (DTA)	9'9"
TRANSPORT HEIGHT	11'10"
SWATH WIDTH	2'-6'

\*DTA - Dismounted Tine Arms

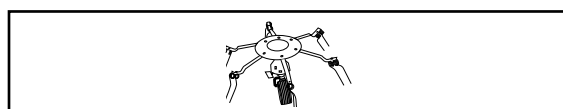

	TINE ARMS PER ROTOR	DOUBLE TINES PER ARM	TIRES OF ROTOR CHASSIS
FRONT	10	4	5 X 16/6.50-8
REAR	12	4	5 X 16/6.50-8

## FELLA

### Dual Rotary Rake Side Delivery and Center Swathing Rakes

FEL-TS1603



#### Features

- Simple swath/height adjustment
- Compact transport
- Semi mount hitch with shaft steering
- Steerable rear wheels
- Wide track rear frame
- Two swath boards, single or double swath
- Warning panels
- Electrical lighting
- Overrunning clutch in the auxiliary drive
- Standard type PTO shaft
- Category 1, 2
- 540 RPM PTO
- Tandem axles with extension
- Jack stand
- Hydraulic folding
- Floating rotor linkage
- HD enclosed greaseable gearbox
- HD removable arms
- Optimum swath formation

Dual Rotary Rake	
PART #	FEL-TS1603
WEIGHT	4,620 LBS
HP RATING	41 HP
CUTTING WIDTH (ONW)	25'3"
CUTTING WIDTH (TW)	27'7"
TRANSPORT LENGTH (MTA)	9'10"
TRANSPORT WIDTH (DTA)	12'
TRANSPORT LENGTH	24'5"
SWATH WIDTH	2'-6'3"
TINE ARMS PER ROTOR	12/12
DOUBLE TINES PER ARM	4/5
TIRES OF ROTOR CHASSIS	4 X 16/6.50-8
TIRES OF TRANSPORT CHASSIS	10.0/75-15.3

\*ONW - One Side Windrow \*TW - Two Windrows

\*MTA - Mounted Tine Arms \*DTA- Dismounted Tine Arms

### 3 Point Rotary Rake

BE-GR320/9



#### Features

- Category 1 & 2; 3PT hitch
- 3 double tines per arm
- Heavy duty frame
- Height adjustment
- Tandem axles with swivel wheels
- Grease-filled gearbox
- PTO with overrunning clutch
- Compact storage / transport width

GR400/11 TANDEM WHEELS



GR400/11 HITCH



#### Rotary Rakes

PART #	BE-GR280/8	BE-GR320/9	BE-GR340/9	BE-GR400/11
WEIGHT	540 LBS	620 LBS	710 LBS	1520 LBS
WORKING WIDTH	9 FT	10 FT	11 FT	13 FT
HP RATING	25-40 HP	35-75 HP	35-75 HP	35-75 HP
HEIGHT ADJUSTMENT	MANUAL	MANUAL	MANUAL	HYDRAULIC
ARMS	8	9	9	11
DOUBLE TEETH/ARM	3	3	3	4



### 3 Point Rotary Rake

BE-GR300DR



### 3 Point Rotary Rake

BE-GR410DR



#### Features

- Category 1 & 2; 3PT hitch
- Heavy duty frame
- Height adjustment
- Swath curtain
- Steel guards
- "T" models are trailed

### 3 Point Rotary Rake

BE-GR410DRT



Rotary Rakes							
PART #	BE-GR250DR	BE-GR300DR	BE-GR330DR	BE-GR330DRTM	BE-GR330DRT	BE-GR410DR	BE-GR410DRT
WEIGHT	616 LBS	704 LBS	748 LBS	836 LBS	880 LBS	1210 LBS	1298 LBS
WORKING WIDTH	8 FT	10 FT	11 FT	11 FT	11 FT	13.5 FT	13.5 FT
HP RATING	20 HP	25 HP	30 HP	30 HP	30 HP	40 HP	40 HP
TANDEM	NO	NO	NO	DUAL WHEEL	DUAL WHEEL	YES	YES
DOUBLE TEETH/ARM	3	3	3	3	3	4	4
ARMS	8	8	9	9	9	11	11

### 3 Point Tedder/Rake

BE-TR300

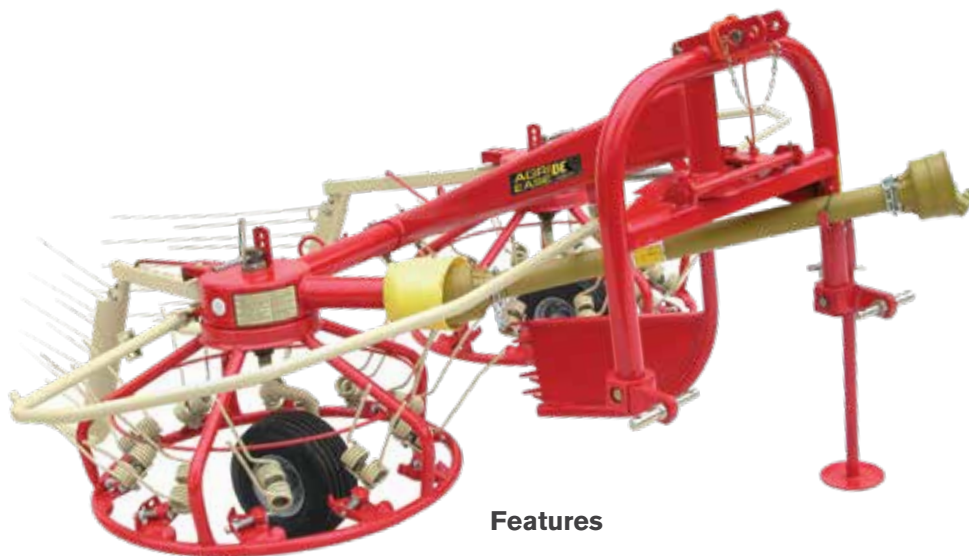

Rotary Rakes	
PART #	BE-TR300
WEIGHT	661 LBS
WIDTH	9'10"
HP RATING	24 HP
TANDEM	NO

#### Features

- Category 1,2; 3PT hitch
- 400-540 RPM PTO
- Jack stand
- Swivel hitch
- Slip clutch PTO height adjustable wheels
- Settings for tedding and raking
- Balloon tires 15 x 6.00-6, 4 ply
- Larger diameter rotor for clean raking

### 3 Point Tedder/Rake

With Tandem Wheel Option

BE-TR300T



Rotary Rakes	
PART #	BE-TR300T
WEIGHT	680 LBS
WIDTH	9'10"
HP RATING	24 HP
TANDEM	YES

### GASPARDO MASCHIO

#### Sickle Mower

GAS-FIORE145

#### Features

- Category 1&2, 3PT hitch
- Adjustable hitch
- Dual drive cutter bar
- 540 RPM PTO
- Belt drive knife
- Manual fold  
("H" model has hydraulic lift)
- Inner and outer skid shoe
- Safety breakaway
- Swath board
- Mow Angle ± 60°



Options	
PART #	GAS-99551004
DESCRIPTION	HYDRAULIC CUTTING BAR LIFT KIT

Sickle Mower						
PART #	GAS-FIORE145	GAS-FIORE175	GAS-FIORE175H	GAS-FIORE205	GAS-FIORE205H	GAS-FIORE235H
WEIGHT	493LBS	511LBS	511LBS	469LBS	469LBS	485LBS
CUTTING WIDTH	4'9"	5'9"	5'9"	6'8"	6'8"	7'6"
CUTTER BAR LIFT	MANUAL	MANUAL	HYDRAULIC	MANUAL	HYDRAULIC	HYDRAULIC

### Disc Mower

FEL-SM168

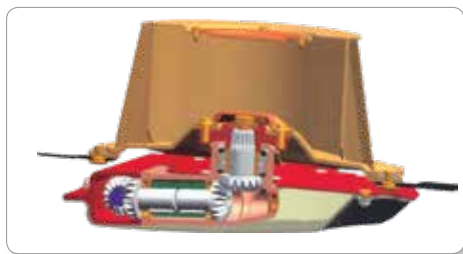

#### Features

- Category 1 & 2, 3PT hitch
- 540 RPM PTO
- Hydraulic folding cylinder
- 2 Blades per disc
- Safety breakaway
- Hardened skids
- Jack stand
- Mow slopes up to 30°
- Large discs with overlap
- Outer rotating swath board
- Gear drive cutter bar
- Optional over running clutch

Disc Mower			
PART #	FEL-SM168	FEL-SM208	FEL-SM248
WEIGHT	818 LBS	895 LBS	961 LBS
HP RATING	30	41	50
KW	22	30	37
WORKING WIDTH	5'5"	6'9"	7'11"
TRANSPORT WIDTH	5'8"	5'8"	5'8"
TRANSPORT HEIGHT	8'1"	9'4"	10'7"
SWATH WIDTH	2'11"	4'1"	5'5"
DISCS	4	5	6
ACRE/HR	5	6	7

### 48" Rotary Tiller

BE-FTL125

#### Features

- 540 RPM PTO
- Manual adjustable hitch
- Parking stand
- Skids for depth control
- 4 blades per flange



CHAIN DRIVE

FTL Rotary Tillers			
PART #	BE-FTL125	BE-FTL135	BE-FTL150
WEIGHT	518 LBS	562 LBS	607 LBS
TILLING WIDTH	47"	51"	59"
HP RATING	15-30 HP	15-30 HP	15-30 HP
TILLAGE DEPTH	3.54"	3.54"	3.54"
BLADES	24	28	32

\*PRODUCT MAY NOT BE EXACTLY AS SHOWN

### 48" Rotary Tiller

BE-TS120

#### Features

- 540 RPM PTO
- Manual adjustable hitch
- Parking stand
- Skids for depth control
- 6 blades per flange
- Gear drive



GEAR DRIVE

TS Rotary Tillers			
PART #	BE-TS120	BE-TS140	BE-TS160
WEIGHT	475 LBS	538 LBS	602 LBS
TILLING WIDTH	48"	56"	64"
HP RATING	20-50 HP	20-50 HP	20-50 HP
TILLAGE DEPTH	6.5"	6.5"	6.5"
BLADES	36	42	48

### Rotary Tiller

BE-TXG40

#### Features

- 6 tines per flange
- Skids for depth control
- Fixed center mount hitch
- Parking stand
- Single speed gearbox
- Comes with 540 RPM slip clutch PTO

Rotary Tiller	
PART #	BE-TXG40
WEIGHT	304 LBS
TILLING WIDTH	40"
HP RATING	23-35 HP
TILLAGE DEPTH	6.5"
BLADES	24



### IGN Rotary Tiller

BE-IGN150

#### Features

- 6 tines per flange
- Skids for depth control
- Fixed center mount hitch
- Parking stand
- Single speed gearbox
- Comes with 540 RPM slip clutch PTO



IGN Medium Duty Rotary Tillers			
PART #	BE-IGN150	BE-IGN180	BE-IGN210
WEIGHT	705 LBS	772 LBS	1235LBS
TILLING WIDTH	59"	71"	82"
HP RATING	30-50 HP	30-50 HP	55 HP
TILLAGE DEPTH	4.75"	4.75"	6.3"
BLADES	36	42	60





### MASCHIO

#### 57" Wide Rotary Tiller Offset

W Series  
MAS-W145

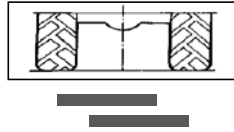

**W SERIES**  
**34"-66"**  
**13-40 HP**



\*PRODUCT MAY NOT BE EXACTLY AS SHOWN

#### Features

- Heavy duty 3PT frame
- Heavy duty single speed gearbox
- 540 RPM PTO
- Skids for depth control
- 4 C-shaped tines per flange (6 on W165)
- Parking stand
- Category 1, universal 3 PT hitch
- PTO shaft with shear pin
- Center or offset mount

W Series Weekender Medium Duty Offset Rotary Tillers				
PART #	MAS-W105	MAS-W125	MAS-W145	MAS-W165
WEIGHT	395 LBS	426 LBS	462 LBS	532 LBS
TILLING WIDTH	42"	50"	58"	66"
HP RATING	15-25 HP	23-40 HP	25-40 HP	30-40 HP
OFFSET SPECS (CM/IN)	53/21-53/21 23/9-83/33	63/25-63/25 22/9-104/41	73/29-73/29 22/9-124/49	83/33-83/33 22/9-144/57

### MASCHIO

#### 50" Rotary Tiller

MAS-A120

**A SERIES**  
**35"-72"**  
**15-60 HP**



\*PRODUCT MAY NOT BE EXACTLY AS SHOWN

#### Features

- Category 1, 3PT hitch
- Adjustable PTO shaft with slip clutch
- Adjustable linkages
- Single speed gearbox with 540 RPM PTO
- 6 C-shaped tines per flange (also available with L-shaped tines)
- Skids for depth control
- Park stand
- #100 Chain drive
- Adjustable side shift

A Series Heavy Duty Commercial Weekender Rotary Tillers					
PART #	MAS-A100	MAS-A120	MAS-A140	MAS-A160	MAS-A180
WEIGHT	503 LBS	543 LBS	593 LBS	660 LBS	715 LBS
WORKING WIDTH	42"	50"	58"	66"	72"
TOTAL WIDTH	47"	55"	63"	71"	79"
HP RATING	20-60	35-60	40-60	45-60	45-60

Optional	Description
MAS-SLIP CLUTCH	OPTIONAL PTO SHAFT CLUTCH IN LIEU OF STANDARD PTO
MAS-99500013	FRONT PAIR DEPTH WHEELS

## MASCHIO

### 53" Rotary Tillers

MAS-H165

**H SERIES**  
**50"-82"**  
**30-70 HP**



#### Features

- Category 1, 2; 3PT hitch
- PTO shaft with slip clutch
- Single speed gearbox
- 6 C-shaped tines per flange  
(also available with L-shaped tines)
- Skids for depth control
- Park stand
- Heavyduty gear drive

#### HEAVY DUTY GEAR DRIVE



#### H Series Medium Duty Commercial Rotary Tillers

PART #	MAS-H125	MAS-H145	MAS-H165	MAS-H185	MAS-H205
WEIGHT	616 LBS	660 LBS	712 LBS	797 LBS	840 LBS
WORKING WIDTH	50"	58"	66"	74"	82"
TOTAL WIDTH	55"	63"	71"	77"	87"
HP RATING	30-60	35-70	40-70	45-70	50-70



## MASCHIO

### 63" Rotary Tiller

MAS-U155

**U SERIES**  
**53"-80"**  
**35-80 HP**

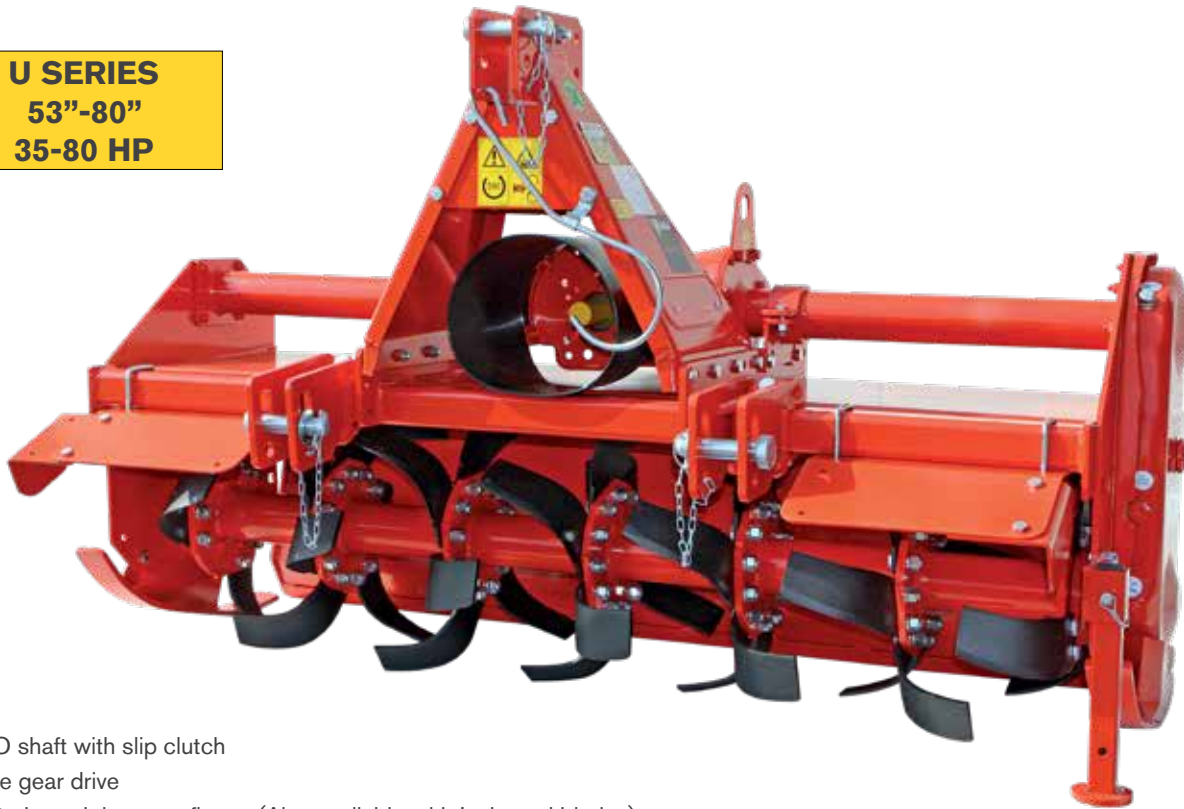

- PTO shaft with slip clutch
- Side gear drive
- 6 C-shaped tines per flange (Also available with L-shaped blades)
- Four speed gearbox with 540 RPM PTO
- Park stand
- Floating lower hitches

**U Series Heavy Duty Commercial Utility Tillers (CM/IN)**

PART #	MAS-U130	MAS-U155	MAS-U180	MAS-U205
WEIGHT	844 LBS	933 LBS	1,022 LBS	1,110 LBS
TILLING WIDTH	135/54	160/63	185/73	210/83
TOTAL WIDTH	146/58	171/68	196/78	221/88
HP RATING	35-80	45-80	50-80	60-80
WORKING DEPTH	22/9	22/9	22/9	22/9
BLADES	30	36	42	48

## MASCHIO

### 93" Rotary Tiller

MAS-B230

**B SERIES**  
**63"-93"**  
**45-100 HP**



- Category 2, 3PT hitch
- PTO shaft with slip clutch
- Side gear drive
- Tailgate hold-down springs
- Adjustable linkages
- 6 C-shaped tines per flange
- Optional rear rollers available
- Four speed gearbox with 540 RPM PTO
- Manual adjust crank for cage roller

**B Series Medium-Heavy Duty Farm Utility Tillers (CM/IN)**

PART #	MAS-B155	MAS-B155WR*	MAS-B180	MAS-B180WR*	MAS-B205	MAS-B205WR*	MAS-B230	MAS-B230WR*
WEIGHT	1,206	1,420	1,356	1,799	1,523	1,990	1,654	2,169
TILLING WIDTH	160/63	160/63	185/73	185/73	210/83	210/83	235/93	235/93
TOTAL WIDTH	173/68	173/68	198/78	198/78	223/88	223/88	248/98	248/98
HP RATING	45-100	45-100	50-100	50-100	60-100	60-100	70-100	70-100
WORKING DEPTH	27/11	27/11	27/11	27/11	27/11	27/11	27/11	27/11
BLADES	36	36	42	42	48	48	54	54

\* "WR" Added Roller – Hex Bar Roller

## MASCHIO

### 72" Rotary Tiller

MAS-C205

**C SERIES**  
**72"-122"**  
**50-130 HP**



#### Features

- Category 2, 3PT hitch
- PTO shaft with slip clutch
- Adjustable linkages
- 6 C-shaped tines per flange
- Tailgate hold-down springs
- Side gear drive
- Manual adjust crank for cage roller
- Multi speed gearbox
- 540 and 1,000 RPM PTO

**C Series Heavy Duty Farm Utility Tillers (CM/IN)**

PART #	MAS-C205	MAS-C205WR*	MAS-C230	MAS-C230WR*	MAS-C250	MAS-C250WR*	MAS-C300	MAS-C300WR*
WEIGHT	1,562	1,738	1,672	1,870	1,780	2,022	1,958	2,332
TILLING WIDTH	210/82	210/82	235/93	235/93	260/102	260/102	310/122	310/122
TOTAL WIDTH	223/88	223/88	248/98	248/98	273/108	273/108	323/127	323/127
HP RATING	60-130	60-130	70-130	70-130	80-130	80-130	100-130	100-130
WORKING	27/11	27/11	27/11	27/11	27/11	27/11	27/11	27/11
BLADES	48	48	54	54	60	60	72	72

\* "WR" Added Roller – Hex Bar Roller

## MASCHIO

### 122" Rotary Tiller

MAS-SC300

**SC SERIES**  
93"-150"  
90-170 HP



#### Features

- PTO shaft with slip clutch
- 540 & 1,000 RPM PTO
- Universal 3PT hitch
- Sidegear drive
- Multi speed gearbox
- 6 C-shaped tines per flange
- Tailgate hold-down springs
- Rear PTO
- Oil cooler (SC380 Only)

SC Series Super Heavy Duty Rotary Tillers (CM/IN)							
PART #	MAS-SC230WR*	MAS-SC250	MAS-SC250WR*	MAS-SC300	MAS-SC300WR*	MAS-SC380	MAS-SC380WR*
WEIGHT	2,458	2,115	2,660	2,425	3,022	3,120	3,880
TILLING WIDTH	235/93	260/102	260/102	310/122	310/122	380/150	380/150
TOTAL WIDTH	248/98	273/108	273/108	323/127	323/127	393/155	393/155
HP RATING	90-170	100-170	100-170	130-170	130-170	150-170	150-170
WORKING DEPTH	28/11	28/11	28/11	28/11	28/11	28/11	28/11
BLADES	54	60	60	72	72	90	90

Optional	Description
MAS-99566025	QUICK HITCH (SC380)

\* "WR" Added Roller – Hex Bar Roller

\* Limited Quantities Available

### MASCHIO

#### 164" Rotary Tiller

MAS-G420WR



4 gear transmission

#### TECHNICAL DATA

G									
	kW	HP	cm	cm	cm	cm	cm	nr.	
275	88-199	120-270	275	300	137,5		137,5	29	66
300	113-199	150-270	310	335	155		155	29	72
350	125-199	170-270	360	385	180		180	29	84
420DT	147-236	200-320	425	460	212,5		212,5	29	96

#### STANDARD EQUIPMENT

Central speed gearbox 1000 rpm PTO with cooling fan  
 Rotor revolutions (rpm): 258  
 Central direct PTO shaft  
 Cam side PTO shaft  
 Side gear drive in synthetic oil bath  
 Heavy duty spherical roller bearings  
 "Duo cone" waterproof sealings, oil bath lubrication  
 Universal three point hitch, cat. III<sup>^</sup> and IV<sup>^</sup>  
 Swinging front hitches  
 Blades thickness 10mm  
 6 blades per flange (side blades are always mounted inwards) Scraper blade, one for each flank  
 Anti-wear skids

Double rear levelling bonnet  
 Double rear levelling bonnet with mechanical adjuster and anti-damages rubber guard  
 Drive cover side protections  
 «CE» safety guards  
 VERSIONE DT:  
 Central track eradicator  
 Double side cam PTO shaft  
 Double side gear drive in synthetic oil bath  
 Double rotor with raised support  
 IMPORTANT: for use on hard or stony soil counter flanges are recommended

## MASCHIO

### 208" Rotary Tiller

MAS-PAN520WR

**PANTERA**  
**189"-248"**  
**220-380 HP**



#### Features

- Single speed gearbox 1,000 RPM PTO
- Folding frame - 103" transport width
- Double side gear drive
- HD main draft shaft
- HD sides shafts with CAM clutch
- 330 RPM rotor speed
- Rear PTO
- Hydraulic roller adjusters
- Center eradicator
- Tungsten coated blades

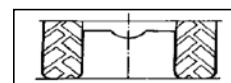

**Pantera Super Heavy Duty Hydraulic Fold Rotary Tiller (CM/IN)**

PART #	MAS-PAN470WR	MAS-PAN520WR	MAS-PAN570WR	MAS-PAN620WR
WEIGHT (LB)	7,660	8,200	8,740	9,360
TILLING WIDTH	478/189	528/208	578/228	630/248
TOTAL WIDTH	510/200	560/220	608/240	660/260
HP RATING	220-380	240-380	260-380	280-380
KW RATING	160-280	176-280	190-280	205-280
WORKING DEPTH	30/12	30/12	30/12	30/12
BLADES	108	120	132	144
CENTER SPECS	239/94	264/104	289/114	315/124

### MASCHIO

#### 59" Power Harrow

MAS-DL1500WR

**DL SERIES**  
**52"-79"**  
**30-100 HP**



#### Features

- Category 1,2; 3PT hitch
- PTO shaft with shear pin
- Adjustable linkages
- Single speed gearbox
- Central hand jack for roller adjustment
- Rear leveling bar with side jack adjustment
- 540 RPM PTO
- Cage roller

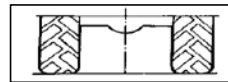

DL Series Power Harrow (CM/IN)				
PART #	MAS-DLV1300WR	MAS-DL1500WR	MAS-DL1800WR	MAS-DL2000WR
WEIGHT	1,010	1,129	1,166	1,202
TILLING WIDTH	132/52	152/60	180/71	200/79
TOTAL WIDTH	137/54	157/62	185/73	205/81
HP RATING	30-100	35-100	45-100	60-100
KW RATING	22-74	26-74	33-74	44-74
WORKING DEPTH	28/11	28/11	28/11	28/11
BLADES	10	12	14	16
CENTER SPECS	66/26	30/76	36/91	40/102

## MASCHIO

### 119" Power Harrow

MAS-DC3000WR

**DC SERIES**  
**99"-119"**  
**80-150 HP**



#### Features

- Category 2, 3PT hitch
- PTO shaft with slip clutch
- Auxiliary rear PTO
- Cage roller
- Rear leveling bar with side jack adjustment
- P.L.U.S. Protection - bolt on deflectors
- Multi speed gearbox
- 540 & 1,000 RPM PTO

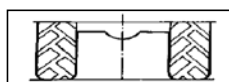

#### DC Series Power Harrow (CM/IN)

PART #	MAS-DC2500WR	MAS-DC2500PR	MAS-DC3000WR
WEIGHT	2,527	2,509	2,838
TILLING WIDTH	250/99	250/99	300/119
TOTAL WIDTH	254/100	254/100	304/121
HP RATING	80-150	80-150	90-150
KW RATING	59-111	59-111	66-111
WORKING DEPTH	28/11	28/11	28/11
BLADES	20	20	24
CENTER SPECS	127/50	127/50	152/60



### MASCHIO

#### 158" Power Harrow

MAS-DM4000WR

**DM SERIES**  
**138"-158"**  
**130-180 HP**



#### Features

- Category 2, 3PT hitch
- PTO shaft with slip clutch
- Auxiliary rear PTO
- Multi speed gearbox
- Rear leveling bar with side jack adjustment
- Side hand jack for roller adjustment
- P.L.U.S. Protection
- 540 & 1,000 RPM PTO
- Hydraulic roller adjustment\*\*

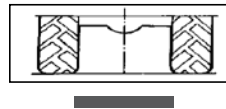

DM Series Power Harrow (CM/IN)					
PART #	MAS-DM3500WR	MAS-DM3500PR	MAS-DM4000WR**	MAS-DM4000SR**	MAS-DM4000PR**
WEIGHT	3,044	3,044	3,331	3,348	3,331
TILLING WIDTH	350/138	350/138	400/158	400/158	400/158
TOTAL WIDTH	355/140	355/140	405/160	405/160	405/160
HP RATING	120-180	120-180	140-180	140-180	140-180
KW RATING	95-132	95-132	105-132	105-132	105-132
WORKING DEPTH	30/12	30/12	30/12	30/12	30/12
BLADES	28	28	32	32	32
CENTER SPECS	175/69	175/69	200/79	200/79	200/79

## MASCHIO

### 119" Power Harrow

MAS-ORSO4500WR

**ORSO**  
119"-178"  
105-185 HP



#### Features

- Category 2, 3PT hitch
- P.L.U.S. Protection
- Double skin gear trough
- 1000 RPM PTO
- Quick blade release with screwed flange
- Gearbox with synthetic oil
- Hydraulic roller adjustment

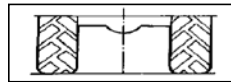

**SPHERICAL ROLLER BEARINGS ALLOW  
30% LONGER LIFE OVER TRADITIONAL  
TAPERED ROLLER BEARINGS**

Orso Power Harrow (CM/IN)		
PART #	MAS-ORSO4500WR	MAS-ORSO4500PR
WEIGHT	4,318	4,907
TILLING WIDTH	450/178	450/178
TOTAL WIDTH	455/180	455/180
HP RATING	150-250	150-250
KW RATING	105-185	105-185
WORKING DEPTH	30/12	30/12
BLADES	36	36
CENTER SPECS	225/89	225/89

### MASCHIO

#### 197" Power Harrow

MAS-AQ5000SR



**AQUILA & TORO**  
**181"-276"**  
**150-380 HP**

#### 197" Power Harrow

MAS-TORO5000

#### Features

- Category 2, 3PT hitch
- Hydraulic folding
- Spiral roller
- PTO slip clutch
- Auxiliary rear PTO
- 2 speed gearbox
- 1,000 RPM PTO
- Rear roller with mechanical adjustment
- Rear level bar with side jack adjustment

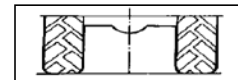

**Aquila & Toro Power Harrow (CM/IN)**

PART #	MAS-AQ5000SR	MAS-AQ6000SR	MAS-TORO7000PR
WEIGHT	6,994	7,859	8,805
TILLING WIDTH	500/197	600/237	700/277
TOTAL WIDTH	512/202	612/241	712/281
TRANS WIDTH	241/95	241/95	241/95
HP RATING	160-380	180-380	250-380
KW RATING	118-198	133-198	184-280
WORK DEPTH	28/11	28/11	30/12
BLADES	40	48	56
CENTER SPECS	250/98.5	300/118	350/138

### Diamond Harrow

HAR40S

ALL NEW DROP  
FORGED HEAVY DUTY  
5/8 X 7" SPIKES



DRAW  
HOOKS

5/8 X 7"  
REPLACEABLE  
TEETH

Diamond Harrow		
PART #	HAR40S	HAR60S
WEIGHT	62 LBS	98 LBS
WORKING WIDTH	40"	60"
LENGTH	52"	52"

### Harrow With Pole

BE-CH8G



#### Features

- 50mm x 6mm tubing
- Powder coated poles

Chain Harrow With Poles - 1/2" x 4-1/2" Tines							
PART #	BE-CH4G	BE-CH6G	BE-CH8G	BE-CH10G	BE-CH12G	BE-CH8LG	BE-CH10LG
SECTION WIDTH	4 FT	6 FT	8 FT	10 FT	12 FT	8 FT	10 FT
POLE COLOR CODE	WHITE	BLACK	GREY	ORANGE	YELLOW	GREY	ORANGE
DEPTH	60"	60"	60"	60"	60"	72"	72"

### Super HD Chain Harrow

BE-CH11G

#### Features

- 45 Degree trash/light harrowing
- 15 Degree rigid/heavy harrowing
- Heavy duty 6mm tubing
- Powder coated colour poles

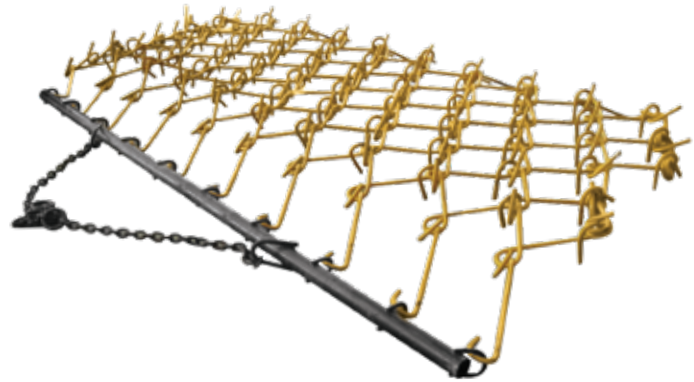

Super HD Chain Harrow With Poles

PART #	BE-CH7G	BE-CH9G	BE-CH11G	BE-CH13G	BE-CH15G
TINES	5/8 2 SIDED TINES	5/8 2 SIDED TINES	5/8 2 SIDED TINES	5/8 2 SIDED TINES	5/8 2 SIDED TINES
SECTION WIDTH	7'	9'	11'	13'	15'
POLE COLOR	GREY	ORANGE	YELLOW	BLUE	GREEN
DEPTH	86"	86"	86"	86"	86"

### 3PT Harrow Carrier

BE-6LHC

3PT Harrow Carrier

PART #	BE-6LHC
WEIGHT	115 LBS
DESCRIPTION	CARRY UP TO 10' CHAIN HARROWS
DEPTH	72"



### Pasture Harrow

4 Way Dutch Cast Harrow

BE-PH06FT

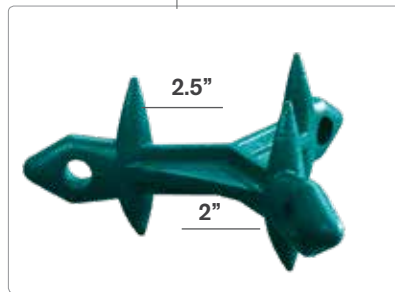
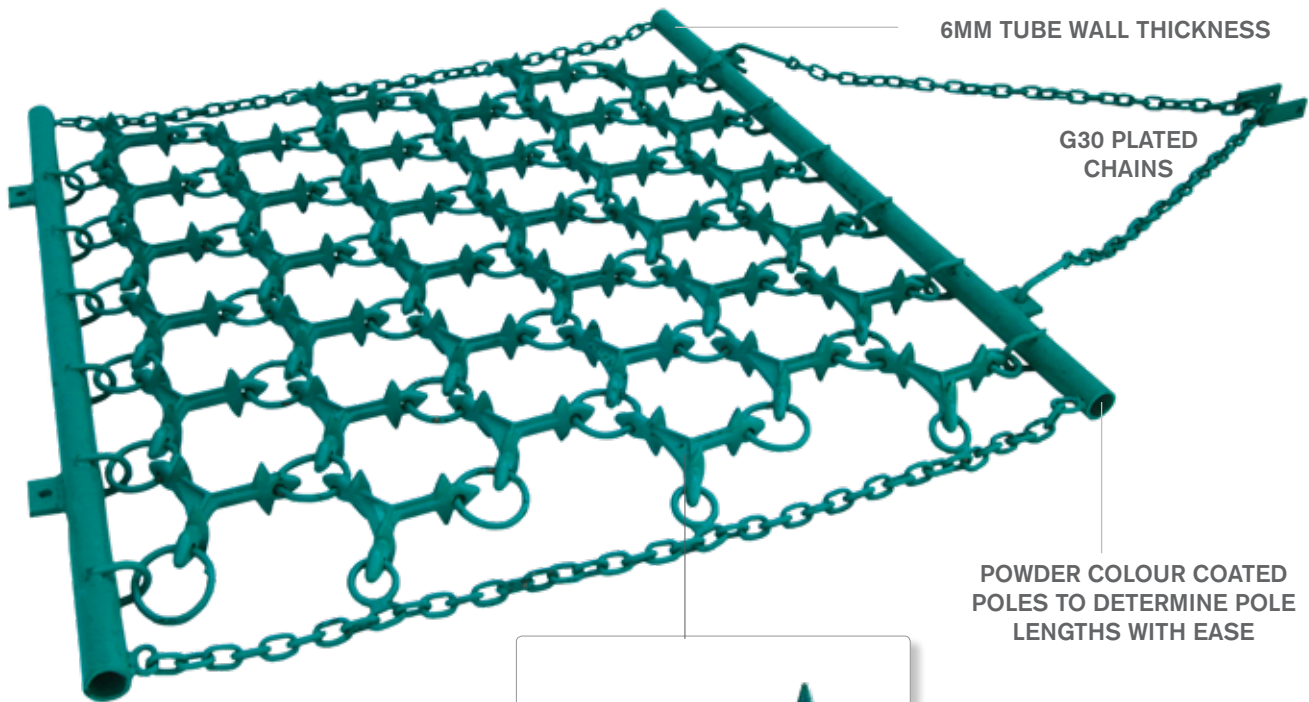

#### Features

- Heavy duty pipe
- Reversible
- Cast star tine
- Level mole hills
- Renovate pasture
- Distributes & pulverizes manure
- 66.5" working depth
- Prepare seed bed
- Extra heavy construction for long life

#### Pasture Harrows

PART #	BE-PH06FT	BE-PH08FT	BE-PH10FT	BE-PH12FT	BE-PH14FT	BE-PH16FT
WEIGHT	297 LBS	396 LBS	495 LBS	594 LBS	643 LBS	693 LBS
WORK WIDTH	6'	8'	10'	12'	14'	16'
POLE COLOR	BLACK	GREY	ORANGE	YELLOW	BLUE	GREEN

### Fertilizer Spreader Poly Hopper

750 lb Capacity  
BE-PFS400G

#### Features

- Category 1, 3PT hitch
- Poly hopper
- Stainless steel insert
- Bottom drop spinner
- Manual controls
- Choice of 3 spread patterns
- 540 PTO

\*Capacity varies with material

Optional Agitator	
PART #	BE-AGI

Fertilizer Spreaders			
PART #	BE-PFS250G	BE-PFS400G	BE-PFS500G
WEIGHT	120 LBS	124 LBS	140 LBS
CAPACITY	550 LBS	750 LBS	1,160 LBS



### Pull Type Spreader

Poly Hopper  
1200 lb Capacity  
BE-PFS501PT

#### Features

- Pull type hitch
- Manual controls
- Poly hopper
- Ground drive
- 23 x 8.50 - 12" Tires
- Bottom drop spreader
- Choice of 3 spread patterns

Pull Type Spreaders	
PART #	BE-PFS501PT
WEIGHT	425 LBS
CAPACITY	1200 LBS (380L)
HOPPER	POLY



### Pendulum Spreader

600 lb Capacity  
BE-PS303



#### Features

- 540 PTO, Category 1 & 2
- 3 PT Hitch
- Polyester reinforced fiberglass hopper
- Agitator
- Broadcast spout

### Pendulum Spreader

950 lb Capacity  
BE-PS403



#### Pendulum Spreaders

PART #	BE-PS303	BE-PS403	BE-PS503	BE-PS603
WEIGHT	176 LBS	270 LBS	278 LBS	285 LBS
CAPACITY	600 LBS (275L)	950 LBS (400L)	1200 LBS (500L)	1320 LBS (600L)
SPREADING WIDTH	25 - 52 FT	24 - 52 FT (SPECIAL 46" WIDE)	24 - 52 FT	24 - 52 FT

#### Optional Remote Control Case

PART #	BE-PS014500

### Pendulum Spreader

1600 Lb Capacity  
BE-PS753



#### Features

- 540 PTO, Cat 2, 3 PT hitch
- Polyester reinforced fiberglass hopper
- Agitator
- Broadcast spout

#### Pendulum Spreaders

PART #	BE-PS753	BE-PS1153	BE-PS1653
WEIGHT	333 LBS	377 LBS	406 LBS
SPREADING WIDTH	24 - 52 FT	24 - 52 FT	24 - 52 FT
CAPACITY	1600 LBS (750L)	2400 LBS (1150L)	3200 LBS (1650L)



#### Optional Remote Control Case

PART #	BE-PS014500

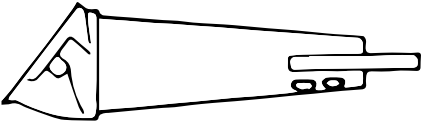
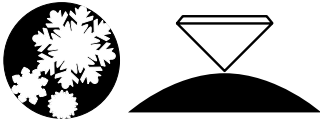

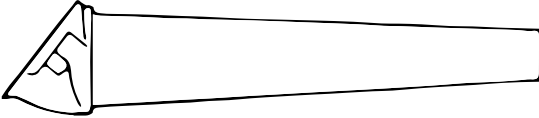
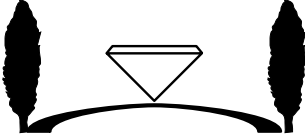
MODEL #	Size	Spreading Width	Material
BE-PS000SG5	11" Broadcast spout	16' - 20'	Stainless Steel
			

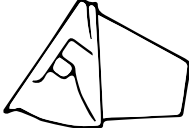
MODEL #	Size	Spreading Width	Material
BE-PS000BS	19" spout for 2 side banding	7' - 35'	Stainless Steel
BE-PS70445	16" spout for 2 side banding	7' - 35'	Nylon
			

MODEL #	Size	Spreading Width	Material
BE-PS000FS	3½" spout for 2 side banding	3' - 5'	Stainless Steel
			

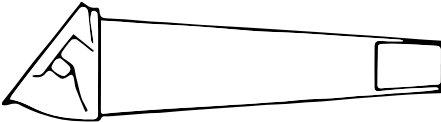
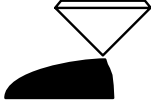
MODEL #	Size	Spreading Width	Material
BE-PS000AL	19" spout for 1 side banding left	0' - 20'	Stainless Steel
			

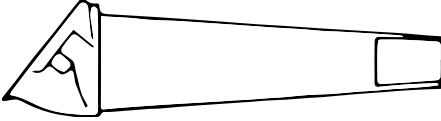
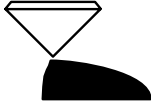
MODEL #	Size	Spreading Width	Material
BE-PS000AR	19" spout for 1 side banding right	0' - 20'	Stainless Steel
			

### 36" Skid Steer Heavy Duty Grapple Bucket

BE-SSGB3236

The grapple bucket is ideal for picking up and moving rocks, logs, brush, debris, and other oddly shaped or hard-to-lift material. The independent grapples make it easy to move difficult and uneven loads.

#### Features

- Universal Skid Steer style hookup
- Greasable pins and bushings
- One cylinder
- Hoses and couplers are included

BE-SSGB3236		
<b>Weight</b>	336 lbs	153 kg
<b>Width</b>	36"	914 mm
<b>Opening Height</b>	32"	813 mm



### 42" Skid Steer Grapple Bucket

BE-SSGB2242

The grapple bucket is ideal for picking up and moving rocks, logs, brush, debris, and other oddly shaped or hard-to-lift material. The independent grapples make it easy to move difficult and uneven loads.

#### Features

- Universal Skid Steer style hookup
- Greasable pins and bushings
- One cylinder
- Hoses and couplers are included

BE-SSGB2242		
<b>Weight</b>	253 lbs	107 kg
<b>Width</b>	42"	1066 mm
<b>Opening Height</b>	22"	559 mm



### 54" Skid Steer Grapple Bucket

BE-SSGB2254

The grapple bucket is ideal for picking up and moving rocks, logs, brush, debris, and other oddly shaped or hard-to-lift material. The independent grapples make it easy to move difficult and uneven loads.

#### Features

- Universal Skid Steer style hookup
- Greasable pins and bushings
- One cylinder
- Hoses and couplers are included

BE-SSGB2254		
<b>Weight</b>	310 lbs	141 kg
<b>Width</b>	54"	1372 mm
<b>Opening Height</b>	22"	559 mm



## 60" Skid Steer Grapple Bucket

BE-SSGB60

BE-SSGB60		
<b>Weight</b>	650 lbs	295 kg
<b>Width</b>	60"	1524 mm
<b>Opening Height</b>	34"	864 mm
<b>Teeth Length</b>	24"	610 mm

### Features

- Universal Skid Steer style hookup
- Hose spring keeps the hydraulic hoses from getting pinched when in use
- Cylinder back stoppers prevent the upper clamps from getting stuck in the upright position or hyperextended.
- Greasable pins and bushings
- Twin 3,000 PSI cylinders
- Hoses and couplers are included



## 72" Skid Steer Grapple Bucket

BE-SSGB72

BE-SSGB72		
<b>Weight</b>	700 lbs	318 kg
<b>Width</b>	72"	1829 mm
<b>Opening Height</b>	34"	864 mm
<b>Teeth Length</b>	24"	610 mm

### Features

- Universal Skid Steer style hookup
- Hose spring keeps the hydraulic hoses from getting pinched when in use
- Cylinder back stoppers prevent the upper clamps from getting stuck in the upright position or hyperextended.
- Greasable pins and bushings
- Twin 3,000 PSI cylinders
- Hoses and couplers are included

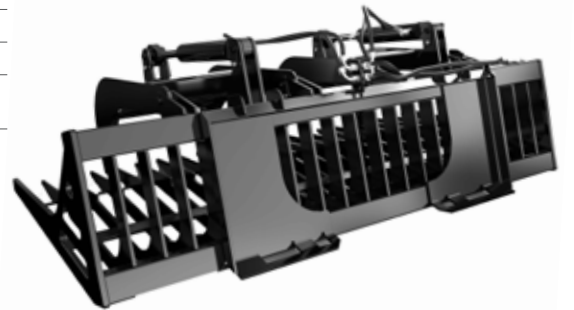

## 84" Skid Steer Grapple Bucket

BE-SSGB84

BE-SSGB84		
<b>Weight</b>	800 lbs	363 kg
<b>Width</b>	84"	2134 mm
<b>Opening Height</b>	34"	868 mm
<b>Teeth Length</b>	24"	610 mm

### Features

- Universal Skid Steer style hookup
- Hose spring keeps the hydraulic hoses from getting pinched when in use
- Cylinder back stoppers prevent the upper clamps from getting stuck in the upright position or hyperextended.
- Greasable pins and bushings
- Twin 3,000 PSI cylinders
- Hoses and couplers are included



### Skid Steer Post Hole Digger

BE-SSPHD4500

- The auger drive unit lets you dig plumb holes with speed and precision. The planetary geared drive powers through tough soil and dirt and keeps the power ready for when you need it. When digging holes, torque means power!

#### Features

- Forged hood ears to cope with the heavy strain of daily use.
- Lockable hood pin makes it almost impossible to detach from your frame.
- Non-dislodgement shaft guarantees the shaft will never fall out, making for a safer work environment.
- Suitable for machines with 7 - 30 GPM hydraulic flow rate.
- Planetary gear box delivers efficient torque and increased reliability.
- 6," 9," 12," 18" and 24" auger bits available.
- 18," 24" and 48" extension posts available.



BE-SSPHD4500

◀ HEX SHAFT

Skid Steer Post Hole Diggers		
<b>Part #</b>	BE-SSPHD3000	BE-SSPHD4500
<b>Torque Range</b>	708 - 2122 ft-lb	1107 - 3319 ft-lb
<b>Oil Pressure</b>	1161 - 3481 PSI	1161 - 3481 PSI
<b>Oil Flow Range</b>	7 - 20 GPM	13 - 30 GPM
<b>Speed Range</b>	36 - 100 RPM	42 - 97 RPM
<b>Unit Height</b>	26"	26"
<b>Unit Width</b>	10"	10"
<b>Unit Weight</b>	157 lbs	166 lbs
<b>Mounting Frame</b>	Fixed Centre Cradle/ Side Shift Cradle	Fixed Centre Cradle/ Side Shift Cradle
<b>Output Shaft Std</b>	2.25" Square 2.56" Round	2.25" Square 2.56" Round
<b>Output Shaft Opt</b>	2" Hex	2" Hex

### Skid Steer Mount Plate Post Hole Digger

BE-SSPHDMP

#### Features

- Frame weight: 145 lbs
- Slide travel distance: 40"



BE-SSPHDMP

SSA6

◀ HEX SHAFT



Hex Shaft Augers					
<b>Part #</b>	SSA6	SSA9	SSA12	SSA18	SSA24
<b>Description</b>	6"	9"	12"	18"	24"

### Skid Steer Tree Spade

BE-SSTS36



**Features**

- 36" wide spade for digging, carrying and planting large saplings, trees and shrubs.
- Allows you to transplant and save trees and shrubs.
- Universal skid steer quick attach style backplate.
- Gusset and reinforced spade and backplate mean this attachment is built to last for years.

BE-SSTS36		
<b>Weight</b>	278 lbs	125 kg
<b>Overall Width</b>	45.4"	1148 mm
<b>Spade Length</b>	36.1"	914 mm
<b>Spade Width</b>	36.8"	934 mm
<b>Spade Tip</b>	5.9"	150 mm
<b>Overall Height</b>	22.7"	577 mm
<b>Overall Length</b>	38.35"	974 mm

### Skid Steer Tree Stump Uprooter

BE-SSTS37



**Features**

- Skid steer Quick Tach mount
- Heavy duty steel body
- Serrated leading edge

The stump bucket for Skid Steer Quick Tach is perfect for uprooting tree stumps, lifting concrete slabs and for digging footing around a house.

The leading edge of the bucket is designed to shred roots and other debris without having to use a saw or shears. The reliable steel construction ensures that this bucket can handle most recreational and professional jobs. Used in construction, landscaping, farming and forestry.

BE-SSTS37		
<b>Total Height</b>	17.85"	453 mm
<b>Total Width</b>	45.47"	1155 mm
<b>Total Length</b>	39.5"	1004 mm
<b>Working Length</b>	37"	940 mm
<b>Working Width</b>	36.5"	927 mm
<b>Weight</b>	164 lbs	74 kg

### Skid Steer Quick Spade

BE-SSQS28

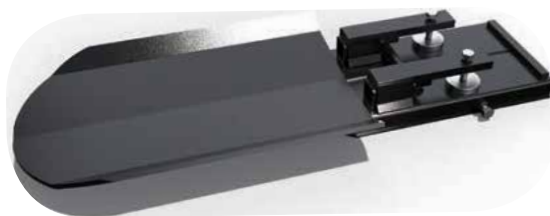

BE-SSQS28		
<b>Weight</b>	98 lbs	45 kg
<b>Total Length</b>	45"	1145 mm
<b>Total Width</b>	17"	433 mm
<b>Total Height</b>	5.2"	132 mm
<b>Spade Working Surface (L x W)</b>	27.5" x 17.75"	698 mm x 451mm

## Skid Steer Grader

BE-SSGS6

The perfect attachment for grading, spreading, leveling, road and parking lot maintenance and more!

### Features

- Triple cutting edge design is the best in the industry.
- Two forward facing edges and one rear facing edge.
- Compact and move material in forward position. Skim and cover skid steer tracks in reverse.
- Fixed pitch design allows you to cut through tough material.
- Bucket stops allow you to transport the bucket on top of the grader.

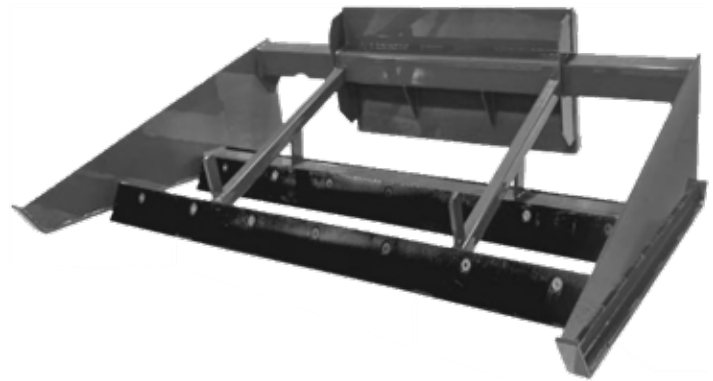

BE-SSGS6		
<b>Weight</b>	710 lbs	322 kg
<b>Grading Width</b>	72"	1829 mm
<b>Overall Width</b>	76.38"	1940 mm
<b>Overall Length</b>	63.15"	1604 mm
<b>Cutting Edge Spread From Front</b>	15" - 35" - 45.8"	381 mm - 889 mm - 1164 mm

## 76" Skid Steer Bale Grabber

BE-SSB76



BE-SSB76		
<b>Working Width Capacity</b>	40" - 76"	1016 mm - 1930 mm
<b>Max Load</b>	1760 lbs	800 kg
<b>Weight</b>	600lbs	273 kg

## Skid Steer Concrete Claw

BE-SSCC52



BE-SSCC52		
<b>Rear Opening Height</b>	9"	229 mm
<b>Working Depth</b>	44"	1118 mm
<b>Working Width</b>	24"	610 mm
<b>Overall Height</b>	22"	559 mm
<b>Overall Depth</b>	52"	1321 mm
<b>Overall Width</b>	47"	1194 mm
<b>Weight</b>	726 lbs	329 kg



## 2200 Lbs Pallet Forks Skid Steer Mount

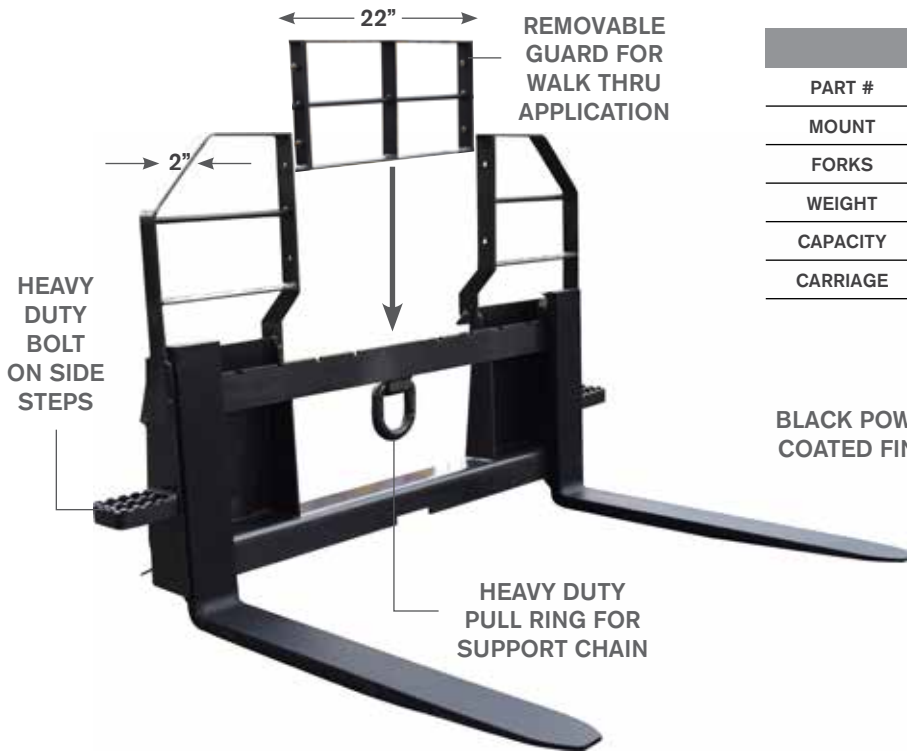

Pallet Forks		
PART #	BE-PF3036LBO500J	BE-PF3042LBO500J
MOUNT	SKID STEER	SKID STEER
FORKS	36"	42"
WEIGHT	284 LBS	310 LBS
CAPACITY	2200 LBS	2200 LBS
CARRIAGE	47" LOCKING	47" LOCKING

BLACK POWDER COATED FINISH

CLASS II LOCKING FORKS



REPLACEABLE STAINLESS LATCH



REPLACEABLE SIDE STEPS

## 3700-4400 Lbs Pallet Forks Skid Steer and EURO Mount



3700-4400 Lbs Skid Steer Versions		
PART #	BE-PF5042LBO500J	BE-PF5048HBO500J
MOUNT	SKID STEER	SKID STEER
FORKS	42"	48"
WEIGHT	387 LBS	440 LBS
CAPACITY	3700 LBS	4400 LBS
CARRIAGE	47" LOCKING	47" LOCKING

EURO Mount Versions		
PART #	BE-HD4442AO600	BE-HD4448AO600
MOUNT	EURO	EURO
FORKS	42"	48"
WEIGHT	430 LBS	466 LBS
CAPACITY	4400 LBS	4400 LBS
CARRIAGE	50" LOCKING	50"

### 5500 Lbs Pallet Forks

Skid Steer and EURO Mount



#### Features

- Comes with guard
- 50" wide carriage
- Sliding adjustable
- 5500 LBS capacity at 24" L.C.
- Tines can be locked in any position
- 1 1/2" X 4" class II solid hook type

HD 5500 Lbs Pallet Forks		
PART #	BE-HD5548B0500	BE-HD5548A0600
MOUNT	SKID STEER	EURO
FORKS	48"	48"
WEIGHT	587 LBS	556 LBS
CAPACITY	5500 LBS	5500 LBS
CARRIAGE	50° LOCKING	50° LOCKING

#### CLASS II LOCKING FORKS



### 42" Loader Pallet Fork

Fits John Deere Mount  
BE-JD3742LAP12F



Pallet Forks			
PART #	BE-JD3742LAP12F	BE-JD3742HAP12F	BE-JD3748HAP12F
MOUNT	FITS JOHN DEERE	FITS JOHN DEERE	FITS JOHN DEERE
FORKS	42"	42"	48"
CAPACITY	3700 LBS	4400 LBS	4400 LBS
CARRIAGE	48° LOCKING	49° LOCKING	49° LOCKING



### Reversible Scoop

BE-RS30G

Reversible Scoop	
PART #	BE-RS30G
WEIGHT	203 LBS
WIDTH	30"
HP RATING	UP TO 40 HP
CAPACITY	10 CUBIC FEET

\*WHILE QUANTITIES LAST

REVERSIBLE SCOOP  
CATEGORY 1, 3PT HITCH  
DUMP LATCH



### Cement Mixer

5 Cubic Ft Capacity

BE-MX320G

Cement Mixer	
PART #	BE-MX320G
WEIGHT	252 LBS
WIDTH	34"
CAPACITY	320L / 84.5 GALLON
HEIGHT	39"
LENGTH	39"

#### Features

- Category 1, 3PT hitch
- 540 RPM PTO shaft
- Parking support stand
- 17" loading mount
- Double acting cylinder with hoses



### Carry-All

3-Point 1000lbs

4CAG

#### Features

- Does not come with plywood deck
- Optimal for carrying
- Angled steel construction

3 Point Carry-Alls	
PART #	4CAG
WEIGHT	65 LBS
MOUNT	3 PT
PINS	CAT 1
SIZE	4' X 3.5'
CAPACITY	1000 LBS



4CAG

### 48" Debris Fork

BE-DF48G

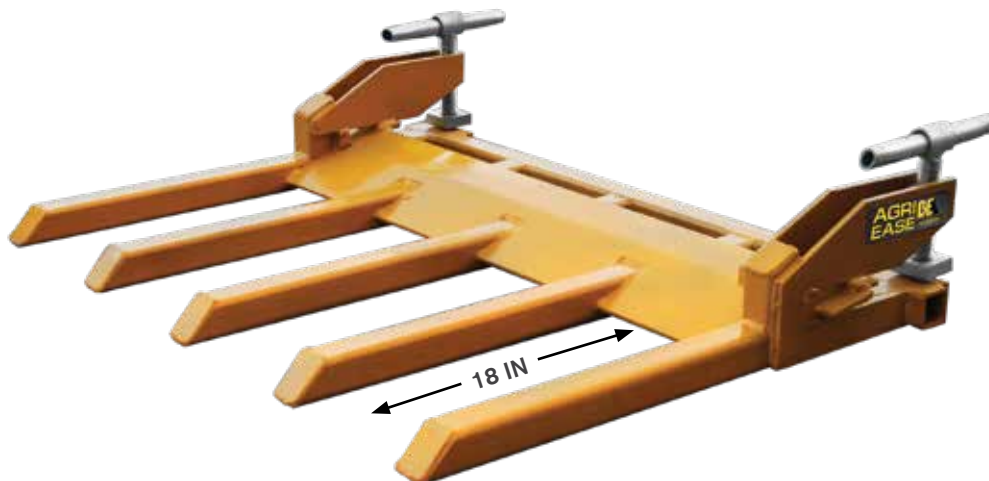

Debris Forks				
PART #	BE-DF48G	BE-DF54G	BE-DF60G	BE-DF72G
WEIGHT	150 LBS	160 LBS	170 LBS	200 LBS
WIDTH	48"	54"	60"	72"
HP	ALL	ALL	ALL	ALL
MOUNT	TO BUCKET	TO BUCKET	TO BUCKET	TO BUCKET
FRAME WIDTH	46"	53.75"	58"	70"
FORK WIDTH	42.5"	50"	54"	67"
FITS BUCKET SIZE	48"+	54"+	60"+	72"+

### 3PT Quick Hitch

Category 2-3

QH2-3G



BOXED EACH  
OR CRATED MASTER QTY



3 Point Quick Hitches						
PART #	QH1G	QH2G	QH2HDG	QH2-3G	QH3NG	QH3G
WEIGHT	72 LBS	139 LBS	163 LBS	197 LBS	176 LBS	184 LBS
WIDTH	29"	36"	36" HD	42"	37"	42"
HP RATING	UP TO 50 HP	UP TO 100 HP	UP TO 130 HP	UP TO 225 HP	UP TO 225 HP	UP TO 225 HP
HITCH	CAT 1	CAT 2	CAT 2	CAT 2-3	CAT 3 NARROW	CAT 3

### 3 Point Pallet & Bin Fork

PART# ABFG



Pallet & Bin Fork		
PART #	ABFG	ABFHDG
CAPACITY	1200 LBS	2000 LBS
HITCH	CAT 1, 3 PT HITCH	CAT 1, 3 PT HITCH
SIZE	L41" X 25" CENTER	L41" X 25" CENTER
FORK SIZE	2"X4" TUBE	1 1/4"X4" SOLID
WEIGHT	90 LBS	174 LBS

### Bucket Ball Mount

PART# 64.500.342



### Bucket Pallet Fork

1000 LBS Each

PART# BFT1000G



Fully  
Boxed

### Bucket Pallet Fork

2000 LBS Each

PART# BFT2000G



Fully  
Boxed



### Fork Extension

2 Meters, 6.6', 110 LBS

PART# EXT3T2M





### 3PT Tow Hooks

CAT 1, Tow Hitch  
Lower Connection  
PART# 64.500.340KITM



### 3PT Tow Hooks

CAT 1, Tow Hitch  
Upper & Lower Connection  
PART# 64.500.341KITM



### 3PT Tow Hooks

CAT 2, HD Tow Hitch  
Upper & Lower Connection  
PART# 64.500.343KITM

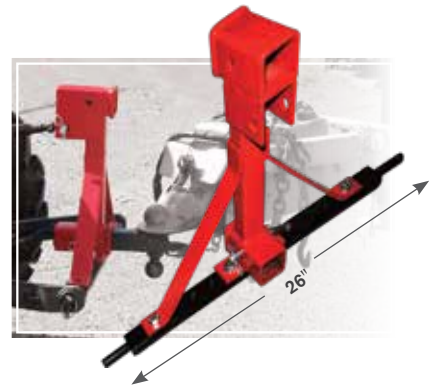

NEW INNOVATIVE,  
**Consumer Friendly**  
RETAIL PACKAGING

**SUPER HOT SELLERS!!**  
3PT HITCH TOW ASSEMBLIES



## Single Bale Spear with Chain

BE-BSBM1G



### Features

- Category 1, 2
- 1-Large 39" tine (34" usable length)
- 2 stabilizer tines

Bale Spears		
PART #	BE-BSBM1G	BE-BSBM2G
WEIGHT	105 LBS	135 LBS
MOUNT	TO BUCKET	TO BUCKET
TINE	SINGLE	DOUBLE
TINE LENGTH	40"	40"
USABLE LENGTH	34"	34"
CHAINS	YES	YES

## 3PT Hitch Bale Spear

BE-BS3PTG



### Features

- Single or double 39" Kvernland prong
- No tool required
- Includes chain & tightener
- Mount to bucket

Bale Spear	
PART #	BE-BS3PTG
WEIGHT	95 LBS
CAPACITY	2500 LBS
HITCH	CAT 1 & 2

### Features

- Skid steer or euro mount
- 39" or 49" length single tine
- Two stabilizer tines
- 2,000 Lbs capacity
- Easy stabbing & removal

Single Prong Bale Spear				
PART #	BE-BSS-39B0500G	BE-BSS-49B0500G	BE-BSS39EU-ROG	BE-BSS49EU-ROG
WEIGHT	148 LBS	150 LBS	148 LBS	150 LBS
MOUNT	SKID STEER	SKID STEER	ALO/EURO	ALO/EURO
TINE LENGTH	39"	49"	39"	49"
USABLE LENGTH	34"	44"	34"	44"

## ALO/Euro Mount 39" Single Prong Bale Spear

BE-BSS39EUROG



### Skid Steer Mount

#### 39" Double Prong Bale Spear

BE-BSD39B0500G



#### Features

- Skid steer or euro mount
- 39" or 49" length double tines
- 2,000 Lbs capacity
- Easy stabbing & removal
- Works with round or square bales
- 30" tine spacing

Double Prong Bale Spear				
PART #	BE-BSD-39B0500G	BE-BSD-49B0500G	BE-BSD39EU-ROG	BE-BSD49EU-ROG
WEIGHT	176 LBS	180 LBS	176 LBS	180 LBS
MOUNT	SKID STEER	SKID STEER	ALO/EURO	ALO/EURO
TINE LENGTH	39"	49"	39"	49"
USABLE LENGTH	34"	44"	34"	44"

Part	Description
BE-BSGUARD	BALE GUARD



### Skid Steer Mount

#### Triple Prong Bale Spear

BE-BST39B0500G



#### Features

- Skid steer or euro mount
- Handles 4' x 4' x 8' bales
- 23" spacing
- 2,000 Lbs capacity

Triple Prong Bale Spear				
PART #	BE-BST-39B0500G	BE-BST-49B0500G	BE-BST39EU-ROG	BE-BST49EU-ROG
WEIGHT	150 LBS	154 LBS	150 LBS	154 LBS
MOUNT	SKID STEER	SKID STEER	ALO/EURO	ALO/EURO
TINE LENGTH	39"	49"	39"	49"
USABLE LENGTH	34"	44"	34"	44"

## Subsoiler

PART# SS1RG



15" Furrower Bottom

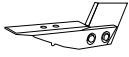

Boxed Each

Subsoiler	
PART #	SS1RG
DEPTH	22" PENETRATION
HP RATING	UP TO 40 HP
WEIGHT	98 LBS
SHANK	1

## Hiller/Middlebuster

PART# MB15G



1/2" x 2 1/2" x 12" Reversible Point

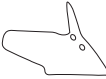

Hiller/Middlebuster	
PART #	BE-MB15G
HP RATING	UP TO 40 HP
WEIGHT	110 LBS
FURROWER	15"

## Subsoiler

1 Shank Heavy-Duty  
BE-SS1HDFK



Call For Availability

Hiller/Middlebuster	
PART #	BE-SS1HDFK
DEPTH	20"

### Features

- Category 1 & 2
- Replaceable point

## ALO/EURO

Weld-On Mount  
PART# WOKAO600



Boxed One Pair Per Box

Euro Weld-On Mount	
PART #	WOKAO600 (PAIR)
DESCRIPTION	ALO & EURO ATTACHMENT
WEIGHT	36 LBS

## Skid Steer

Weld-On Adaptor Plate  
PART# ABSS



Boxed Each

Weld-On Skid Steer Adaptor Plate	
PART #	ABSS
HEIGHT	18-7/8"
WIDTH	47-1/4"
DEPTH	3-1/8"

### 5 Ton Logsplitter 115V CSA Approved

LS5TELL

#### Features

- 115V, 60hz
- 1300W power output
- 12A rated current
- 3400 RPM
- 2700 PSI
- 3.8L oil capacity
- 2.2" cylinder bore x 17" stroke
- 14S cycle time
- Auto return standard valve type
- 110 lb shipping weight



#### Splitter Stand

LS5TELLSTAND



#### 4 Way Wedge Option

LS4ELLWEDGE



### 7 Ton Logsplitter 115V CSA Approved

LS7TELL

#### Features

- 115V, 60hz
- 1300W power output
- 13.5A rated current
- 3400 RPM
- 2700 PSI
- 3.8L oil capacity
- 2.2" cylinder bore x 17" stroke
- 14S cycle time
- Auto return standard valve type
- 117 lb shipping weight





### 16 Ton 2-Way Log Splitter

BE-LS16TL6505GC

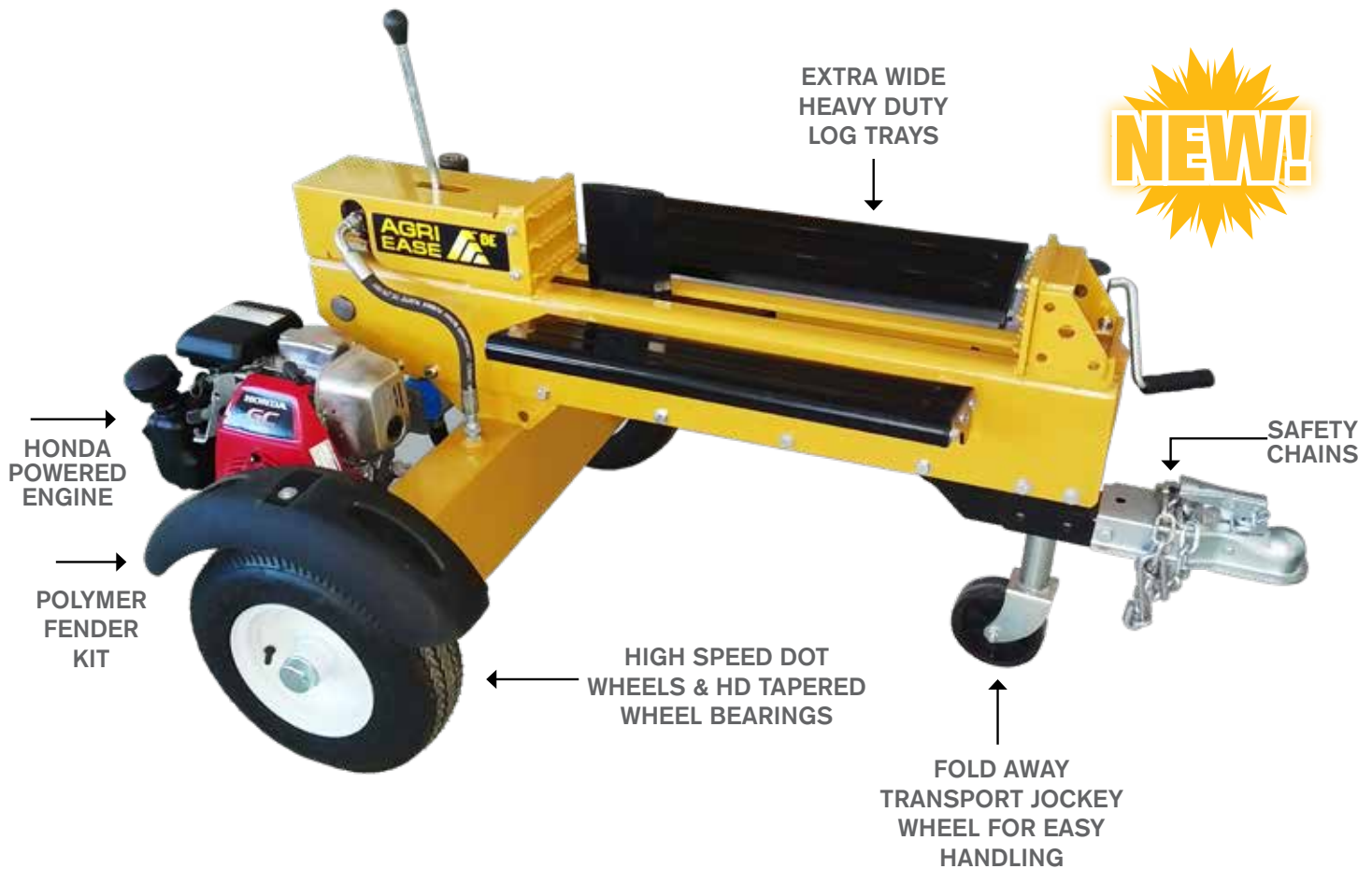

#### Features

- Extra wide heavy duty log trays
- Full beam
- Polymer fender kit
- DOT tires
- Honda powered engine
- Comes with oil
- Ready to operate
- HD tapered wheel bearing

16 Ton Logsplitters		
Part #	BE-LS16TL6505GC	BE-LS16TL6565GX
Weight	350 lbs	350 lbs
Engine	Honda GC160	Honda GX200
Split Force	16 ton	16 ton
Log Length	20"	20"
Wedge Height	6.5"	6.5"
Cylinder	3.5 x 18"	3.5 x 18"
Pump	11 GPM Hi-Low	11 GPM Hi-Low
Max Pressure	3400 PSI	3400 PSI
Cycle Time	5.5 seconds	5.5 seconds

### 22 Ton 3Pt Hitch Logsplitter With Hydraulic Hoses & QD Tips

BE-LS22TL3PT



#### Features

- 22 ton splitting force
- 8" wedge height
- Horizontal or vertical frame
- 25" log length
- 375 lbs

MIN  
6 GPM  
REQUIRED



#### 4 Way Wedge Option

LS4LWEDGE-NS



## 25 Ton Log Splitter

BE-LS25TLE5GC



POWERED by **HONDA**

### Tow Behind Snowblower

Part #	BE-LS25TLE5GC
Engine	Honda GC160 160cc
Split Force	25 ton
Log Length	24"
Wedge Height	7"
Cylinder	4 X 22"
Pump	9 GPM Hi-Lo
Max Pressure	3400 PSI

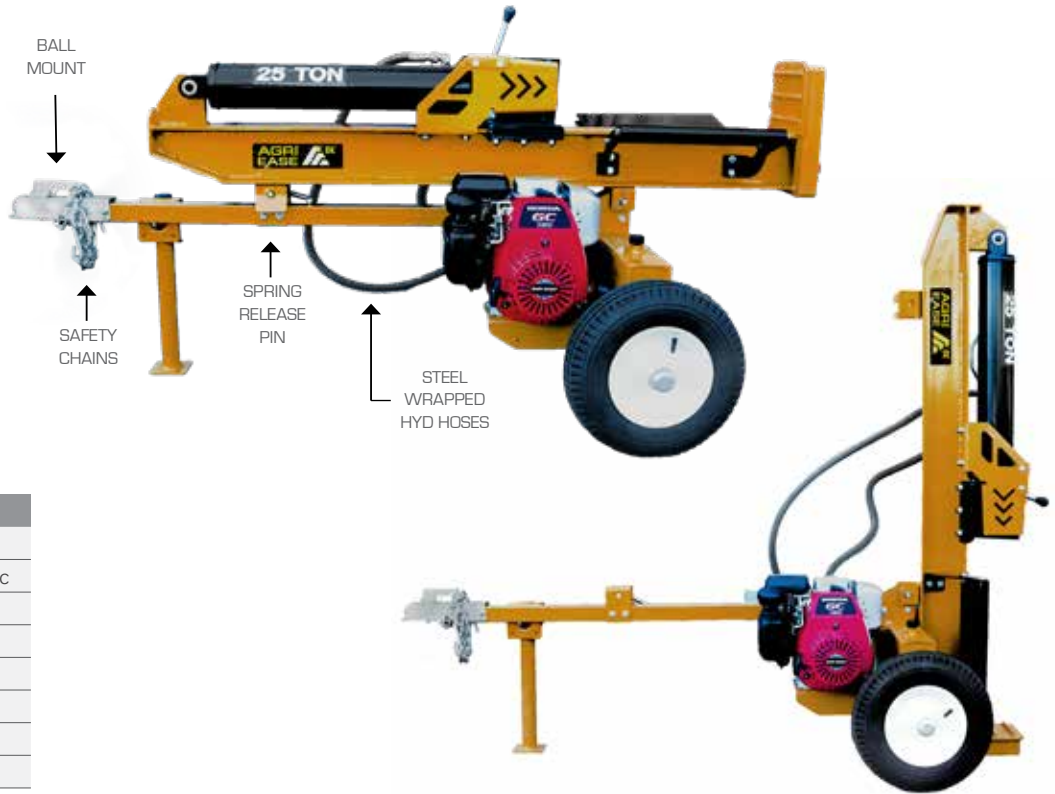

## 25 Ton Log Splitter

BE-LS25TLE65GX



POWERED by **HONDA**

### Tow Behind Snowblower

Part #	BE-LS25TLE65GX
Engine	Honda GX200 200cc
Split Force	25 ton
Log Length	24"
Wedge Height	7"
Cylinder	4 X 22"
Pump	9 GPM Hi-Lo
Max Pressure	3400 PSI



### Features

- Honda powered engine
- Durable heavy duty log trays
- Off road pneumatic wheels
- Full beam
- Hydraulic oil included
- Minimal set up required
- Heavy duty tapered wheel bearing
- 3 position control with automatic ram return
- Wire wrapped hydraulic hose
- Over top engineered log dislodger
- Vertical and horizontal operation

## 22-34 Ton Deluxe Log Splitters

Honda Powered Log Splitters

STARTING AT

### 4 Way Wedge Option

LS4LWEDGE-NS



#### Features

- Extra wide heavy duty log trays
- Full beam
- Heavy duty rear lights with steel guards
- Polymer fender kit
- D.O.T. tires
- Honda powered engine
- Comes with oil
- 4 way wedge optional
- Ready to operate
- Heavy duty tapered wheel bearing
- 3 position control with auto ram return
- Wire wrapped hydraulic hose
- New engine protection cover
- New easy lift handle coming soon

Tow-Behind Logsplitter						
Part #	BE-LS22TL65070	BE-LS22TL6505GC	BE-LS22TL65065GX	BE-LS28TL6506GC	BE-LS28TL65065GX	BE-LS34TL6509GX
<b>Weight</b>	518 lbs	518 lbs	518 lbs	551 Lbs	551 Lbs	633 Lbs
<b>Engine</b>	Power Ease 210cc	Honda GC160 160cc	Honda GX200 200cc	Honda GC190 190cc	Honda GX200 200cc	Honda GX270 270cc
<b>Split Force</b>	22 ton	22 ton	22 ton	28 ton	28 ton	34 ton
<b>Log Length</b>	25"	25"	25"	25"	25"	25"
<b>Wedge Height</b>	8"	8"	8"	8"	8"	8"
<b>Cylinder</b>	4 x 24"	4 x 24"	4 x 24"	4.5 x 24"	4.5 x 24"	5 x 24"
<b>Pump</b>	9 GPM Hi-Lo	9 GPM Hi-Lo	9 GPM Hi-Lo	11 GPM Hi-Lo	11 GPM Hi-Lo	16 GPM Hi-Lo
<b>Max Pressure</b>	3400 PSI	3400 PSI	3400 PSI	3450 PSI	3450 PSI	3500 PSI
<b>Cycle Time</b>	13 seconds	13 seconds	13 seconds	13 seconds	13 seconds	11 seconds

## 35 Ton Economy Powered Log Splitters

Honda Powered Log Splitters

BE-LS35TLE270GX

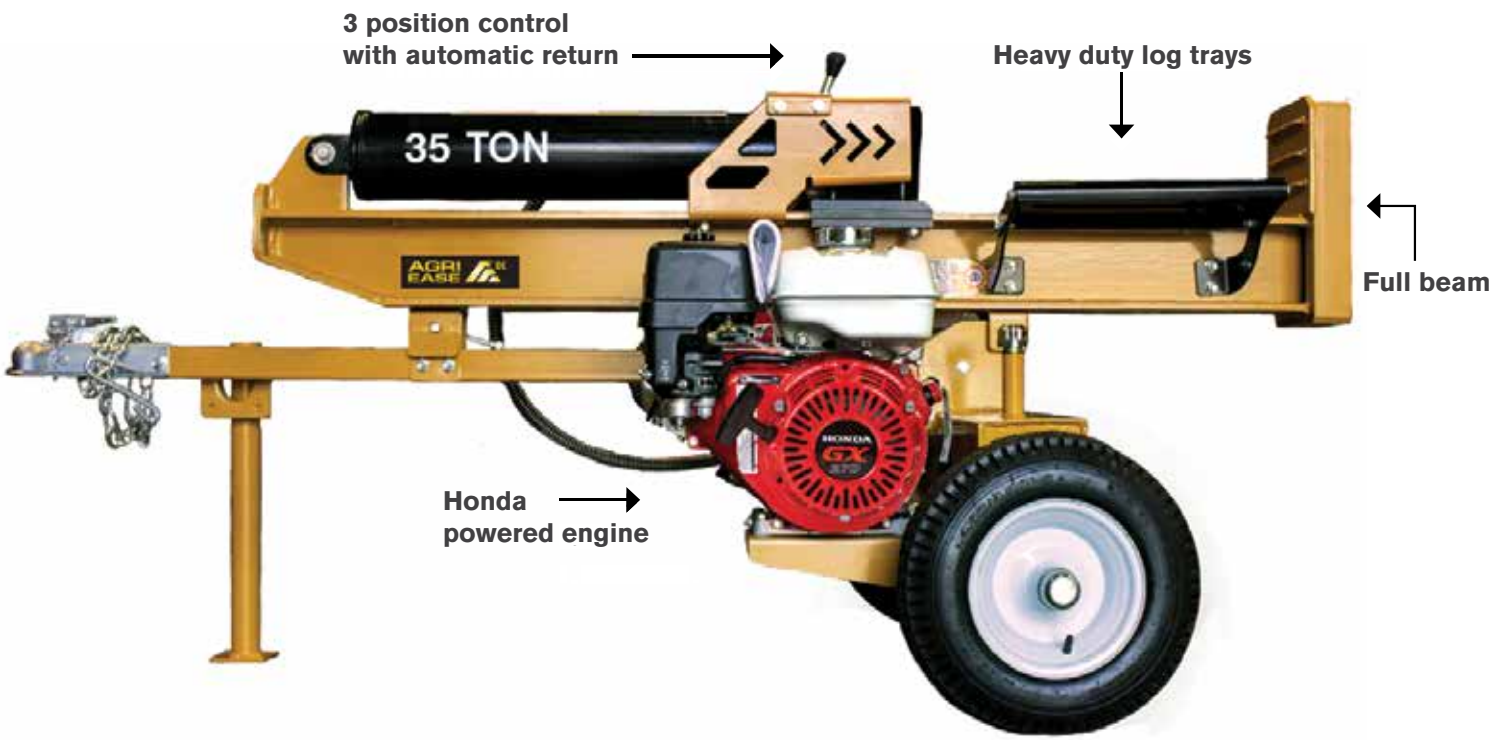

POWERED by **HONDA**

BE-LS35TLE270GX	
ENGINE	HONDA GX270 270CC
SPLIT FORCE	35 TON
LOG LENGTH	25"
WEDGE HEIGHT	8"
CYLINDER	5 X 24"
PUMP	16 GPM HI-LO
MAX PRESSURE	3500 PSI
CYCLE TIME	11 SECONDS



### FEA TURES

- HD log trays
- Full beam
- Honda powered commercial engine
- Ready to operate
- HD tapered wheel bearing
- 3 Position control w/auto ram return

### 3-Point Snowblower

50" Light Weight  
BE-SBS50GL



#### Light Weight Snowblower

Light Weight Snowblower	
PART #	BE-SBS50GL
IMPELLER DIAMETER	20"
CHUTE ROTATION	MANUAL
NUMBER OF STAGES	2
WEIGHT	425 LBS

#### Features

- Cat 1; 3PT hitch
- PTO driven
- 2 stages
- Adjustable chute deflector
- Adjustable rear skid shoes
- Replaceable cutting edge

### 3-Point Snowblower

BE-SBS50G



#### Features

- Cat 1, 3 PT hitch
- 540 RPM PTO
- Skid shoes
- Single auger

Width Extensions	
<b>PART #</b>	BE-SBSEXTG
<b>DESCRIPTION</b>	NEW 2" WIDTH EXTENSIONS AVAILABLE FOR YOUR BE SNOWBLOWER. INCREASE WIDTH BY 4"

Options	
<b>PART #</b>	SBSNHYDKIT
<b>DESCRIPTION</b>	HYDRAULIC CHUTE ROTATION KIT

Snowblowers					
<b>PART #</b>	BE-SBS50G	BE-SBS60G	BE-SBS72G	BE-SBS76G	BE-SBS7680G
<b>WEIGHT</b>	505 LBS	545 LBS	585 LBS	620 LBS	645 LBS
<b>WIDTH</b>	50"	60"	72"	76"	80"
<b>HP RATING</b>	18 HP	22 HP	40 HP	45 HP	50 HP
<b>CHUTE</b>	MANUAL	MANUAL	MANUAL	MANUAL	MANUAL



### 3-Point Snowblower

BE-SBS86HDG

REMOVABLE  
TELESCOPING  
HITCH



HD BLOWER



INCLUDES TOOL FREE  
H.D. HEIGHT ADJUSTABLE  
SKIDS



HYDRAULIC CHUTE  
ROTATION STANDARD

HYDRAULIC DEFLECTOR  
SPOUT OPTIONAL



#### Features

- Manually adjustable deflect spout
- Hydraulic operated chute
- Removable hitch
- 540 Shear bolt torque limited PTO
- Includes skid shoes

Options	
PART #	SBSHDGDEFKIT
DESCRIPTION	HYDRAULIC DEFLECTOR SPOUT KIT

Heavy Duty Snowblowers		
PART #	BE-SBS86HDG	BE-SBS100HDG
WEIGHT	1650 LBS	1900 LBS
WIDTH	86"	100"
HP RATING	50-80 HP	50-80 HP
CHUTE	HYDRAULIC	HYDRAULIC



## 3 Point 4" Wood Chipper BE-WC42G

### Features

- Category 1, 3 PT hitch
- 540 RPM PTO
- 360° rotating hood
- Self feeding
- 1 fixed blade, 4 rotating blades
- Special hardened blade



Wood Chippers	
PART #	BE-WC42G
WEIGHT	432 LBS
HP RATING	18-45 HP
CAP	4"
FEED	GRAVITY
ROTOR	25 1/2" DIA

## 3 Point 5" Wood Chipper BE-WC522

### Features

- Category 1, 3 PT hitch
- 540 RPM PTO
- 360° rotating hood
- Self feeding
- 1 fixed blade, 4 rotating blades
- Special hardened blade



Wood Chippers		
PART #	BE-WC62G	BE-WC522
WEIGHT	1067 LBS	860 LBS
HP RATING	30-100 HP	30-100 HP
CAP	6"	5.2"
FEED	GRAVITY	HYDRAULIC
ROTOR	30" DIA	25" DIA

### Post Hole Digger

BE-PHDLG

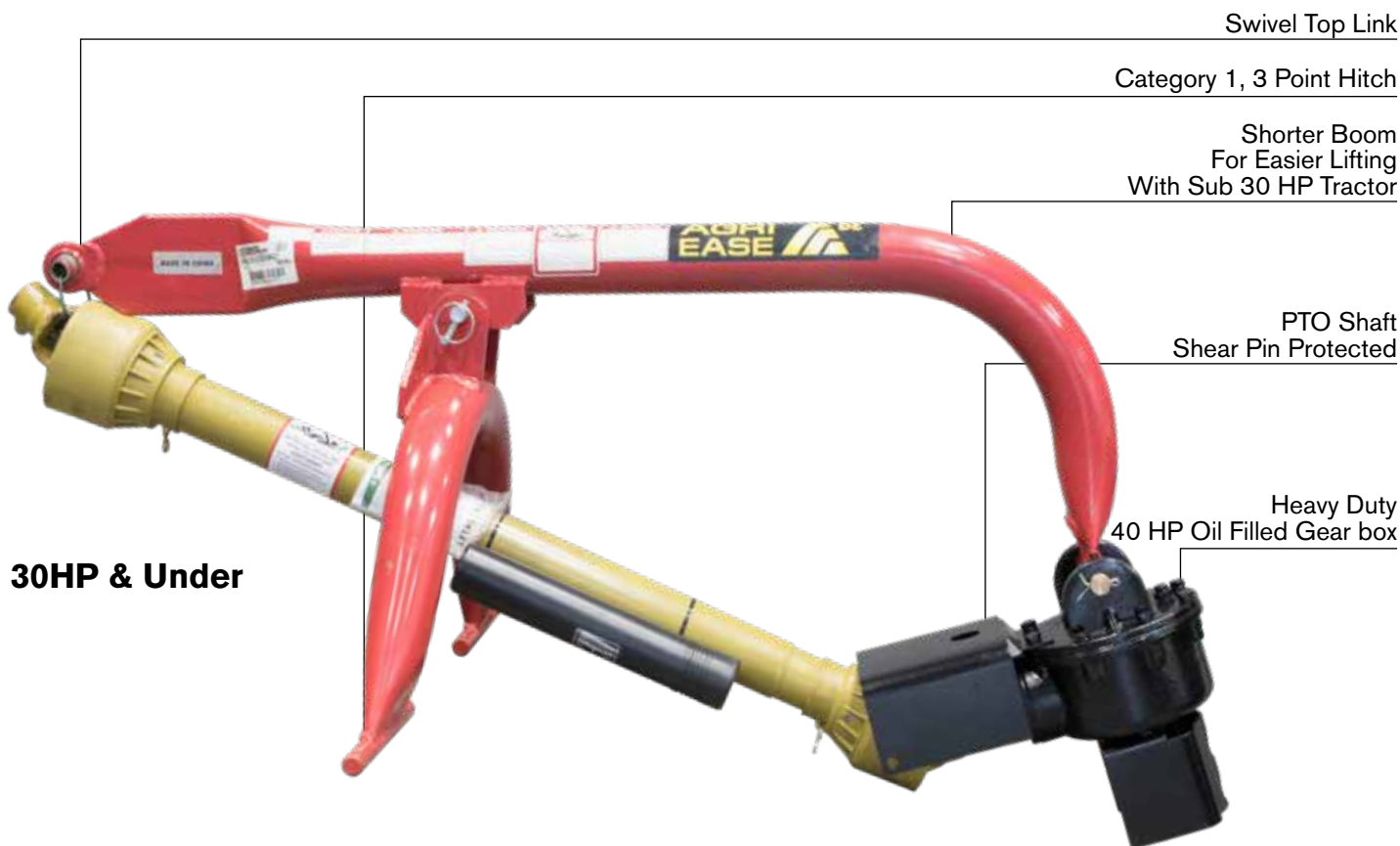

BOXED INDIVIDUALLY



▪ 2 PIECES PER CRATE

Post Hole Digger	
Part #	BE-PHDLG
Weight	135 lbs
Drilling Depth	40"

Augers				
Part #	Product Name	Weight	Drilling Depth	
PHA6SG	6" Auger	21 lbs	24"	
PHA9SG	9" Auger	28 lbs	24"	
PHA12SG	12" Auger	43 lbs	24"	

### Post Hole Digger

BE-PHDG

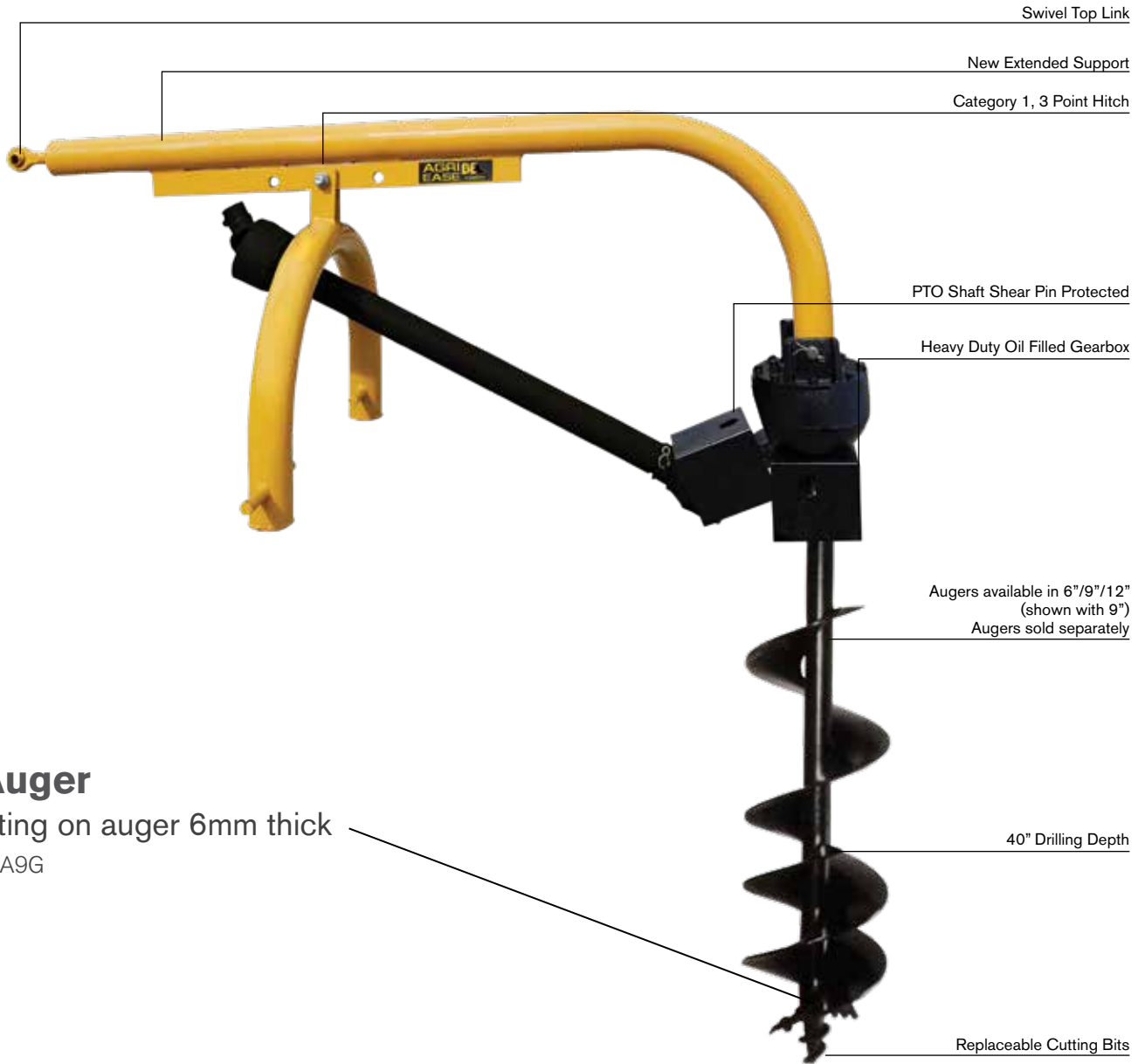

### 9" Auger

Flighting on auger 6mm thick

BE-PHA9G

Post Hole Digger	
<b>Part #</b>	BE-PHDG
<b>Weight</b>	155 lbs
<b>Drilling Depth</b>	40"

Augers				
Part #	Product Name	Weight	Drilling Depth	
BE-PHA6G	6" Auger	32 lbs	40"	
BE-PHA9G	9" Auger	40 lbs	40"	
BE-PHA12G	12" Auger	52 lbs	40"	

### 9 Gal. Spot Sprayer

90.700.100



#### Features

- 12V DC pump
- Replacement drain fitting with cap
- Trigger gun with 20" chrome lance
- Nozzle adjusts from mist to solid stream
- 15' of 1/4" coiled hose
- 5" screw on lid

Agriease Spot Sprayers	
PART #	90.700.100
CAPACITY	9 GAL.
SPRAY	ADJ. NOZZLE
PUMP	12V DC PUMP

### 9 Gal. Master Gardener Sprayer

90.710.009



ADJUSTABLE  
HANDLE HEIGHT

50" SPRAY

#### Features

- Rechargeable 12V battery
- 2 hr run time on single charge
- Front mounted nozzle with 50" swath
- Spot spray gun with coiled hose
- 18' vertical and 20' horizontal spray
- Includes hitch bar for towing
- Adjustable handle for easy storage
- 12" wheels
- 9 Gal. Tank

Agriease Spot Sprayers	
PART #	90.710.009
CAPACITY	9 GAL.
SPRAY	ADJ. NOZZLE
PUMP	12V DC PUMP

### Features

- Chemical resistant polyethylene tank
- Ideal for applying insecticides and herbicides
- Molded wand clips
- 12V connection cables
- Adjustable cone spray nozzle
- 15' hose with U45050000 Gun
- 18" lever hand gun
- 1.0 GPM 12V pump

### 15 Gallon Tank Model

90.700.150



Spot Sprayers		
<b>PART #</b>	90.700.150	90.700.250
<b>CAPACITY</b>	15 GALLONS	25 GALLONS
<b>PUMP</b>	DELAVAN 1.0GPM, 12V	DELAVAN 1.0GPM, 12V
<b>DESCRIPTION</b>	COMES WITH 15' HOSE	COMES WITH 15' HOSE

Spot Sprayer Boom Kits			
<b>PART #</b>	90.700.303	90.700.302	90.700.304
<b>DESCRIPTION</b>	ATV MOUNTING KIT	7FT COVERAGE BOOM, 2 NOZZLES. USE WITH A MIN 1.8GPM PUMP*	10FT COVERAGE FOLDING BOOM, 3 NOZZLES. USE WITH A MIN 1.8GPM PUMP*

\*MUST UPGRADE TO A MINIMUM 1.8 GPM PUMP WHEN USING BOOM KITS.

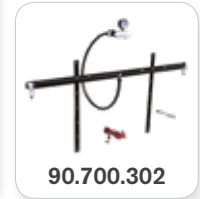
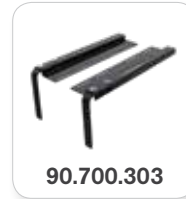

### Features

- ATV sprayer with boom & brackets
- 2.2 GPM 12V pump
- 2 nozzle fixed boom (90.712.250)
- 3 nozzle folding boom (90.713.250)
- Chemical resistant polyethylene tank
- Molded wand clips
- 12V connection cables
- Standard deflect nozzle
- 18" handgun
- 15' hose

### 25 Gallon ATV Sprayer

90.712.250



ATV Skid Mount Sprayers		
<b>PART #</b>	90.712.250	90.713.250
<b>CAPACITY</b>	25 GALLONS	25 GALLONS
<b>BOOM</b>	2 NOZZLE FIXED	3 NOZZLE FOLDING



### 40 Gallon ATV Mounted Sprayer with Boom and Spot Wand BE-RTVMS40



**Boxed**  
Minor Assembly Required

#### Features

- Poly Tank
- Adjustable skid frame
- Everflo 12V pump
- 2.2 GPM / 8.3 LPM  
70 PSI / 4.5 bars
- Fits most RTV boxes
- Adjustable relief with gauge
- 3-Piece, 80" folding boom,  
3 nozzles
- Includes remote switch
- Handgun with hose
- Adjustable height
- Rubber bumpers ensure a snug fit  
over the RTV tailgate to minimize  
sliding in box



**FLEXIBLE  
SPRING  
LOADED  
BOOM**

#### ATV Sprayers

PART #	BE-RTVMS40	BE-RTVMS60
CAPACITY	40 GALLONS	60 GALLONS
PUMP	EVERFLO 12V	EVERFLO 12V

### 40 Gallon Skid Mount Sprayer BE-SMSE40-10

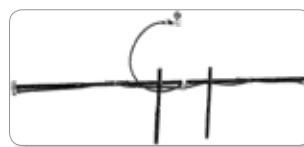

#### Features

- 15' Hose with U45050000 Gun
- 10' Coverage Boom, 3 Section
- 1.8 or 2.0 GPM 12V Pump
- Boom, 120" Spray
- Pressure Control

#### Skid Mount Sprayers

PART #	BE-SMSE40-10	BE-SMSE60-10
CAPACITY	40 GALLONS	60 GALLONS

## 25 Gallon Tank Model

90.800.250

### Features

- 15' hose with U45050000 gun
- 2.0 GPM 12V pump
- 84" boom spray coverage
- Powder coated frame
- 10" pneumatic tires
- Pressure gauge

Trailer Sprayers		
<b>PART #</b>	90.800.150	90.800.250
<b>CAPACITY</b>	15 GALLONS	25 GALLONS
<b>PUMP</b>	DELAVAN 2.0GPM, 12V	DELAVAN 2.0GPM, 12V
<b>DESCRIPTION</b>	COMES WITH 15' HOSE	COMES WITH 15' HOSE
<b>WEIGHT</b>	60LBS	72LBS

**Deluxe Folding Boom & Boomless Nozzles Available. Contact For Further Details**



## 40 Gallon Trailer Lawn Sprayer

90.800.400

### Features

- Chemical resistant polyethylene tank
- Adjustable cone spray nozzle
- Glyphosate compatible
- On-Off boom control
- 120" boom spray coverage
- 3 Section folding breakaway boom
- Adjustable pressure with return to tank
- 18" Handgun with 15 ft of hose
- Deluxe handgun option

REPLACEMENT TIP PART# 90.140.025



**Boxed**  
Minor Assembly Required

### 40 Gallon 3 pt Sprayer

Includes Boom & 12V Pump

BE-RMES40



#### Features

- Chemical resistant polyethylene tank
- Round up ready
- Pressure control and gauge
- 3 section, 3 nozzle folding boom
- Adjustable cone spray nozzle
- On/off boom controls
- Adjustable pressure relief valve
- Molded wand clips
- 18" pistol handgun with 15' hose
- 12V or roller pump
- 10 ft coverage
- 3 PT frame

### 60 Gallon 3 Point Sprayer

Includes Boom & 12V Pump

BE-RMES60



**ALL MODELS COME WITH  
PUMP, FLOW CONTROL  
VALVE, SPOT GUN & BOOM**

3-Point Sprayers				
PART #	BE-RMES40	BE-RMS40	BE-RMES60	BE-RMS60
WEIGHT	45 LBS	45 LBS	60 LBS	60 LBS
CAPACITY	40 US GALLON	40 US GALLON	60 US GALLON	60 US GALLON
PUMP	12V	ROLLER PUMP	12V	ROLLER PUMP



### 150 Gallon Sprayer

Includes 28 ft Boom  
BE-RM150-28FB

#### Features

- 28 ft boom
- Folding wet boom design
- 8 way selector valve
- Category 1, 2; 3PT hitch
- 3 section control
- In-line strainer
- Round Up ready
- No-drip fan nozzles
- Quick exchange nozzle bodies
- Chemical resistant polyethylene tank



3-Point Sprayers		
PART #	BE-RMS150-28FB	BE-RMS200-28FB
WEIGHT	450 LBS	590 LBS
CAPACITY	150 GALLON	200 GALLON
BOOM	28'	28'
# OF NOZZLES	17	17
PUMP	6900C ROLLER PUMP INCLUDED COMPLETE WITH COUPLER AND TORQUE BAR	



## IDEAL FOR APPLYING INSECTICIDES & HERBICIDES



### 3pt Boom Sprayers

N105

HAR-BNL50NB



- All pumps are diaphragm
- This is only a sample of a wide selection of sprayers and options available from Hardi.  
Please see the Hardi catalog or contact Braber for all your sprayer needs.

Model	Capacity	Pump	Boom	Tires	Gun/Controls
HAR-BNL50NB	53 GALLON	4.2 GPM	--	--	HANDGUN/25'
HAR-BNL50/14	53 GALLON				
HAR-N105/NB	105 GALLON				
HAR-N105/20	105 GALLON	8.2 GPM	20' MANUAL FOLD	--	MANUAL
HAR-N105/26	105 GALLON	8.2 GPM	26' MANUAL FOLD	--	MANUAL
HAR-N155/26	155 GALLON	26 GPM	26' MANUAL FOLD	--	MANUAL
HAR-N155/33	155 GALLON	8.2 GPM	33" MANUAL FOLD	--	MANUAL
HAR-N210/26	210 GALLON	26 GPM	26" MANUAL FOLD	--	MANUAL
HAR-N210/33	210 GALLON	26 GPM	33' MANUAL FOLD	--	MANUAL

### Skid Mount Sprayer

BE-SMS200

#### Features

- Comes with filter, fittings, and agitator kit



**\*ENGINE & PUMP KIT  
SOLD SEPARATELY**

Model	Capacity
BE-SMS100	100 GALLON
BE-SMS150	150 GALLON
BE-SMS200	200 GALLON

### FLORIDA

#### 600L/160 US GAL Mist Blower FLO-PLN600EL



#### Features

- Two speed gearbox
- Nylon fan type 730 less clutch
- Swivel clevis hitch
- 10 Brass double nozzles with spraying system D3-D5 tips
- Adjustable width axle
- Built-in hand wash tank
- Galvanized frame
- APS series pump
- M/170 alum manual lever control & regulator mounted to tractor
- Parking jack
- MA50/2 2 speed GB with neutral point
- External suction filter with non return valve
- External level gauge
- Hydraulic agitation inside tank
- Adjustable drawbar with fork fitting

\*Actual capacity varies by material

Standard Trailed Mist Blowers			
PART #	FLO-PLN600EL	FLO-PLN800EL	FLO-PLN1000EL
WEIGHT	1,020	1,050	1,180
WIDTHS	44"	48"	51.2"
CAPACITY	160 US GALLON	200 US GALLON	260 US GALLON
AGITATOR	HYDRAULIC	HYDRAULIC	HYDRAULIC
PUMP	APS 96	APS 96	APS 96
FAN	28"	28"	28"

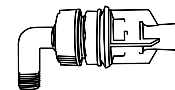

AGITATOR

## FLORIDA

### Deluxe Trailer Mist Blower

FLO-PLN1000MA



#### Features

- Aluminum fan
- Two speed gearbox
- Stainless steel booms
- Pull type
- Flotation types
- Twin flip-over nozzles
- Galvanized frames
- Swivel clevis hitch
- Jack stand with wheel

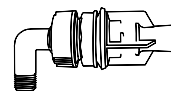

AGITATOR

#### Deluxe Trailer Mist Blowers

PART #	FLO-PLN1000MA	FLO-PLN1500
WEIGHT	1,200	1,400
CAPACITY	260 US GALLONS	400 US GALLONS
AGITATOR	---	---
PUMP	APS 145	BP 151/20
FAN	---	---

### FLORIDA

#### 200L Mist Blower FLO-AEP200



#### Features

- 3PT hitch econo model
- 8 Single nozzles
- Nylon fan
- Poly tank
- Comet APS 51 pump
- Hydraulic agitator

\*Actual capacity varies by material

3-Point Mist Blowers			
PART #	FLO-AEP200	FLO-AEP300	FLO-AEP400
WEIGHT	320 LBS	364 LBS	450 LBS
HP	25-35 HP	25-50 HP	30-80 HP
MIN WORKING WIDTH	42"	48"	56"
CAPACITY	200 L / 50 US GAL	300 L / 75 US GAL	400 L / 105 US GAL
FAN SIZE(CM/IN)	24"	24"	24"
DIMENSIONS (CM/IN)	42" W X 48" D X 48" H	42" W X 50" D X 48" H	56" W X 52" D X 60" H



### 200L 3PT Sprayer

FLO-SS200NB

#### Includes

- Hose Bracket
- High Pressure Hose
- Spray Gun
- COMET BP75 Pump



### 200L 3PT Sprayer

with 15 ft folding boom

FLO-BS200/15

#### Includes

- 15 ft Folding Boom
- Hose Bracket
- High Pressure Hose
- Spray Gun
- COMET BP75 Pump
- 4 Way Controls



### 400L 3PT Sprayer

FLO-SS400NB

#### Includes

- Hose Bracket
- High Pressure Hose
- Spray Gun
- 3 Way Control
- COMET BP75 Pump



### 400L 3PT Sprayer

with 20 FT folding boom

FLO-BS400/20

#### Includes

- Hose Bracket
- High Pressure Hose
- Spray Gun
- 20ft Folding Boom
- COMET BP75 Pump



## BOOM KITS

### Pair Of Side Spraying Booms

With 4+4 Nozzles

FLO-SSB4+4

### 15 ft Herbicide Folding Boom

FLO-4.5MHKIT

### 20 ft Folding Boom Kit

FLO-6MHKIT

### FLORIDA

#### 600L 3PT Sprayer

FLO-SS600NB



**Includes**

- Hose Bracket
- High Pressure Hose
- Spray Gun
- BP75 Pump
- 3 Way Control

#### 600L 3PT Sprayer with 26 ft folding boom

FLO-BS600/26



**Includes**

- Hose Bracket
- High Pressure Hose
- Spray Gun
- ECM 4 Way Control
- 26 ft Folding Boom
- COMET BP75 Pump

#### 800L 3PT Sprayer

FLO-SS800NB



**Includes**

- Hose Bracket
- High Pressure Hose
- Spray Gun
- COMET BP75 Pump
- ECM 4 Way Control

#### 800L 3PT Sprayer with 33 ft folding boom

FLO-BS800/33



**Includes**

- High Pressure Hose
- Spray Gun
- COMET BP125 Pump
- ECM 4 Way Control

### BOOM KITS

#### 26 ft Folding Boom Kit

FLO-8MKIT

#### 33 ft Folding Boom Kit

FLO-10MKIT



### 9.9 Ft<sup>3</sup> Dump Cart

TC5010



### 14 Ft<sup>3</sup> Heavy Duty Dump Cart

TC5014HD



### 5 Gallon Livestock Waterer

81.000.015





**600 Lb Poly Dump Cart**  
TCP600



**1500 Lb Poly Dump Cart**  
TCP1500



**1000 Lb Poly Dump Cart**  
TCP1000



**1200 Lb Poly Dump Cart**  
TCP1200



**1200 Lb Poly Dump Cart**  
with Four Wheels  
TCP12004W



**1500 Lb Poly Dump Cart**  
with Four Wheels  
TCP15004W





# **EQUIPMENT**

**CATALOG 2019 44<sup>TH</sup> EDITION**

**2019**

2019

# EQUIPMENT

CATALOG 2019 44<sup>TH</sup> EDITION





# EQUIPMENT CATALOG

## 2019 44<sup>TH</sup> EDITION



**VISIT YOUR LOCAL DEALER FOR MORE INFORMATION**

Blank area for local dealer information.

LOCAL DEALER

Braber Equipment Ltd.  
Abbotsford, BC, Canada  
Toll Free: 1.877.588.3311  
Phone: 604.850.7770  
Fax: 604.850.7774

Braber Equipment Ltd.  
Kitchener, ON, Canada  
Toll Free: 1.800.367.6089  
Phone: 519.624.8383  
Fax: 519.624.7510

Braber Equipment Ltd.  
Shakopee, MN  
Toll Free: 1.877.588.3311  
Phone: 604.850.7770  
Fax: 60.850.7774

Braber Equipment Ltd.  
1980 SE 4th Ave.  
Canby, OR, USA 97013  
Toll Free: 1.877.588.3311  
Toll Free Fax: 1.800.665.7334  
Phone: 952.426.3523  
Fax: 1.604.850.7774

**TOLL FREE FAX 1.800.665.7334**  
**E-mail: [wgsales@brabereq.com](mailto:wgsales@brabereq.com)**  
**WWW.BRABEREQ.COM**